

Extending Surface Area and Volume



Then **Now** **Why? ▲**

You identified and named three-dimensional figures and calculated surface area and volume for some common solids.

- In this chapter, you will:
 - Find lateral areas, surface areas, and volumes of various solid figures.
 - Investigate Euclidean and spherical geometries.
 - Use properties of similar solids.

ARCHITECTURE Architects use different types of solids to create designs that are both interesting and functional.

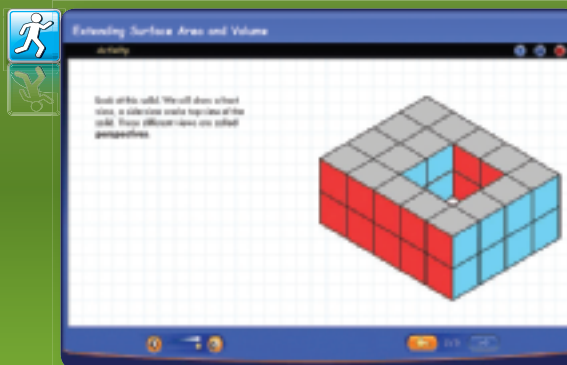

connectED.mcgraw-hill.com

Your Digital Math Portal

Animation



Vocabulary



eGlossary



Personal Tutor



Virtual Manipulatives



Graphing Calculator



Audio



Foldables



Self-Check Practice



Worksheets



Get Ready for the Chapter

Diagnose Readiness | You have two options for checking prerequisite skills.

1 Textbook Option Take the Quick Check below. Refer to the Quick Review for help.

QuickCheck

Determine whether each statement about the figure in Example 1 is *true*, *false*, or *cannot be determined*.

- $\square ABCD$ lies in plane \mathcal{M} .
- $\square CDHG$ lies in plane \mathcal{N} .
- \overline{AB} lies in plane \mathcal{M} .
- \overline{HG} lies in plane \mathcal{N} .
- $\overline{AE} \perp$ to plane \mathcal{M} .
- $\overline{DC} \parallel$ line ℓ .

QuickReview

Example 1

In the figure, $\overline{AD} \perp \ell$ and $ABCDEFGH$ is a cube. Determine whether plane $\mathcal{M} \perp$ plane \mathcal{N} .

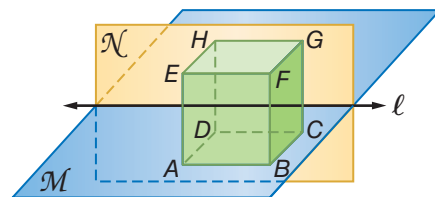

Plane $\mathcal{M} \perp$ plane \mathcal{N} cannot be determined from the given information.

Find the area of each figure. Round to the nearest tenth if necessary.

-
-

- CRAFTS** A seamstress wants to cover a kite frame with cloth. If the length of one diagonal is 16 inches and the other diagonal is 22 inches, find the area of the surface of the kite.

Find the value of the variable in each equation.

- $a^2 + 40^2 = 41^2$
- $8^2 + b^2 = 17^2$
- $a^2 + 6^2 = (7\sqrt{3})^2$

Example 2

Find the area of the figure. Round to the nearest tenth if necessary.

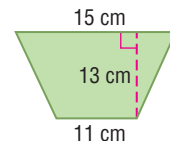

$$\begin{aligned}
 A &= \frac{1}{2}h(b_1 + b_2) && \text{Area of a trapezoid} \\
 &= \frac{1}{2}(13)(15 + 11) && \text{Substitution} \\
 &= \frac{1}{2}(13)(26) && \text{Simplify.} \\
 &= 169 && \text{Multiply.}
 \end{aligned}$$

The area of the trapezoid is 169 cm^2 .

Example 3

Find the value of the variable in $8^2 + 7^2 = c^2$.

$$\begin{aligned}
 c^2 &= 8^2 + 7^2 && \text{Original equation} \\
 c^2 &= 64 + 49 && \text{Evaluate the exponents.} \\
 c^2 &= 113 && \text{Simplify.} \\
 c &= \pm\sqrt{113} && \text{Take the square root of each side.}
 \end{aligned}$$

2 Online Option Take an online self-check Chapter Readiness Quiz at connectED.mcgraw-hill.com.



Get Started on the Chapter

You will learn several new concepts, skills, and vocabulary terms as you study Chapter 12. To get ready, identify important terms and organize your resources. You may refer to Chapter 0 to review prerequisite skills.

FOLDABLES StudyOrganizer



Surface Area and Volume Make this Foldable to help you organize your Chapter 12 notes about surface area and volume. Begin with one sheet of notebook paper.

1 Fold the paper in half.



2 Fold the paper again, two inches from the top.

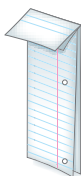

3 Unfold the paper.



4 Label as shown.

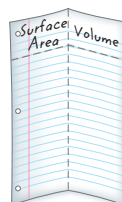

New Vocabulary



English		Español
right solid	p. 837	sólido recto
oblique solid	p. 838	sólido oblicuo
isometric view	p. 839	vista isométrica
cross section	p. 840	sección transversal
lateral face	p. 846	cara lateral
lateral edge	p. 846	arista lateral
altitude	p. 846	altura
lateral area	p. 846	área lateral
axis	p. 848	eje
regular pyramid	p. 854	pirámide regular
slant height	p. 854	altura oblicua
right cone	p. 856	cono recto
oblique cone	p. 856	cono oblicuo
great circle	p. 881	círculo mayor
Euclidean geometry	p. 889	geometría euclidiana
spherical geometry	p. 889	geometría esférica
similar solids	p. 896	sólidos semejantes
congruent solids	p. 896	sólidos congruentes

Review Vocabulary



regular polyhedron **poliedro regular** a polyhedron in which all of the faces are regular congruent polygons

6 square faces

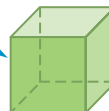

4 equilateral triangular faces





We can relate some three-dimensional solids to two-dimensional figures with which we are already familiar. Some three-dimensional solids can be formed by translating a two-dimensional figure along a vector.

A **right solid** has base(s) that are perpendicular to the edges connecting them or connecting the base and the vertex of the solid. Some right solids are formed by translating a two-dimensional figure along a vector that is perpendicular to the plane in which the figure lies.

Activity 1

Identify and sketch the solid formed by translating a horizontal rectangle vertically.

To help visualize the solid formed, let a playing card represent the rectangle, and lay it flat on a table so that it is horizontal. To show the translation of the rectangle vertically, stack other cards neatly, one by one, on top of the first.

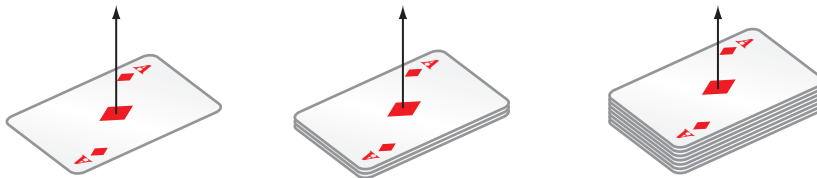

Notice that the solid formed is a right rectangular prism, which has a rectangular base, a translated copy of this base on the opposite side parallel to the base, and four congruent edges connecting the two congruent rectangles. These edges are parallel to each other but perpendicular to the bases. A sketch of the figure is shown.

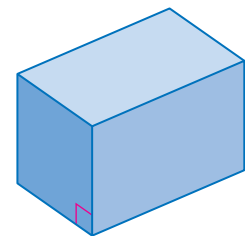

Model and Analyze

1. Use congruent triangular tangram pieces to identify and sketch the solid formed by translating a horizontal triangle vertically.
2. Use the coins from a roll of quarters to identify and sketch the solid formed by translating a horizontal circle vertically.

Identify and sketch the solid formed by translating a vertical two-dimensional figure horizontally.

3. rectangle

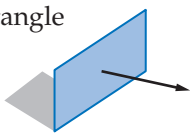

4. triangle

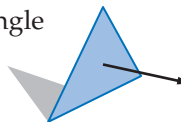

5. circle

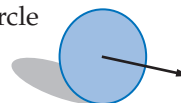

6. **REASONING** Are the solids formed in Exercises 3, 4, and 5 right solids? Explain your reasoning.

(continued on the next page)

An **oblique solid** has base(s) that are not perpendicular to the edges connecting the two bases or vertex. An oblique solid can be formed by translating a two-dimensional figure along an oblique vector that is neither parallel nor perpendicular to the plane in which the two-dimensional figure lies.

Activity 2

Identify and sketch the solid formed by translating a horizontal rectangle along an oblique vector.

Let a playing card represent the rectangle. Lay it flat on a table so that it is horizontal. To show the translation of the rectangle along an oblique line, stack other cards one by one on top of the first so that the cards are shifted from the center of the previous card the same amount each time.

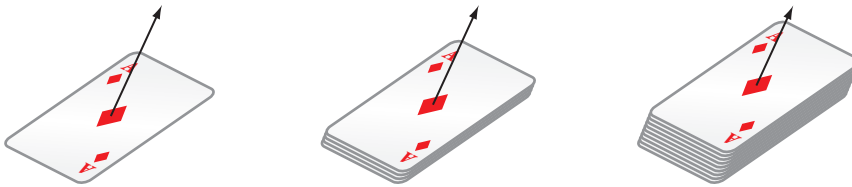

The solid formed is an oblique rectangular prism, which has a rectangular base, a translated copy of this base on the opposite side parallel to the base, and four congruent edges connecting the two congruent rectangles. These edges are parallel to each other but oblique to the bases. A sketch of the figure is shown.

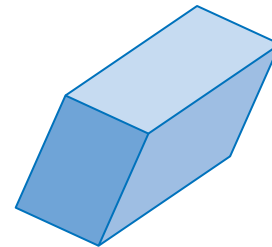

Model and Analyze

Identify and sketch the solid formed by translating each vertical two-dimensional figure along an oblique vector. Use concrete models if needed.

7. triangle

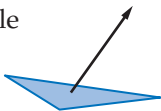

8. circle

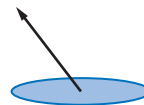

Identify each solid as *right*, *oblique*, or *neither*.

9.

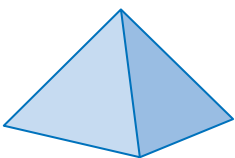

10.

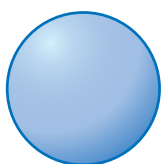

11.

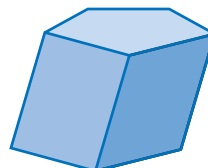

12. **REASONING** Can a pyramid with a square base be formed by translating the base vertically? Explain your reasoning.

Representations of Three-Dimensional Figures

Then

- You identified parallel planes and intersecting planes in three-dimensional figures.

Now

- 1 Draw isometric views of three-dimensional figures.
- 2 Investigate cross sections of three-dimensional figures.

Why?

- Video game programmers use technology to make the gaming environments appear three-dimensional. As players move in the various video game worlds, objects are realistically shown from different perspectives.



New Vocabulary

isometric view
cross section



Common Core State Standards

Content Standards

G.GMD.4 Identify the shapes of two-dimensional cross-sections of three-dimensional objects, and identify three-dimensional objects generated by rotations of two-dimensional objects.

Mathematical Practices

- 5 Use appropriate tools strategically.
- 1 Make sense of problems and persevere in solving them.

1 Draw Isometric Views In video games, three-dimensional figures are represented on a two-dimensional screen. You can use isometric dot paper to draw **isometric views**, or corner views, of three-dimensional geometric solids on two-dimensional paper.



front view



isometric view



Example 1 Use Dimensions of a Solid to Sketch a Solid

Use isometric dot paper to sketch a triangular prism 3 units high with two sides of the base that are 2 units long and 4 units long.

Step 1

Mark the corner of the solid. Draw 3 units down, 2 units to the left, and 4 units to the right. Then draw a triangle for the top of the solid.

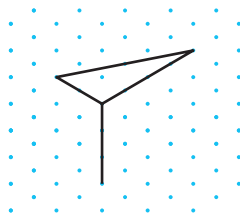

Step 2

Draw segments 3 units down from each vertex for the vertical edges. Connect the appropriate vertices using a dashed line for the hidden edge.

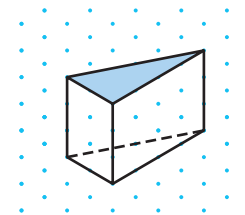

Guided Practice

1. Use isometric dot paper to sketch a rectangular prism 1 unit high, 5 units long, and 4 units wide.

Recall that an *orthographic drawing* shows the top, left, front, and right views of a solid. You can use an orthographic drawing to draw an isometric view of a three-dimensional figure. The top, front, and right views of a cube are shown at the right.

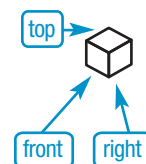



Example 2 Use an Orthographic Drawing to Sketch a Solid

Use isometric dot paper and the orthographic drawing to sketch a solid.

- top view: There are two rows and two columns. The dark segments indicate that there are different heights.
- left view: The figure is 3 units high on the left.
- front view: The first column is 3 units high and the second column is 1 unit high.
- right view: The figure is 3 units high on the right. The dark segments indicate that there are breaks in the surface.

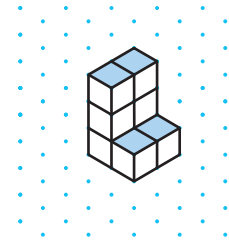
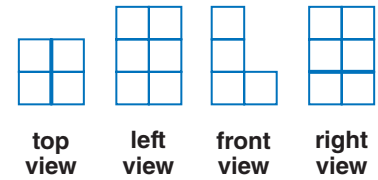

Connect the dots on the isometric dot paper to represent the edges of the solid. Shade the tops of each column.

Guided Practice

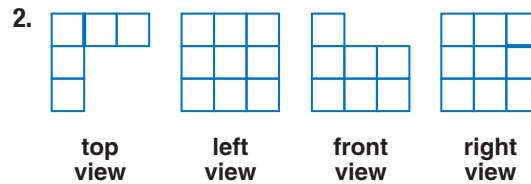

2 Investigate Cross Sections A **cross section** is the intersection of a solid and a plane. The shape of the cross section formed by the intersection of a plane and a three-dimensional figure depends on the angle of the plane.



Real-World Example 3 Identify Cross Sections of Solids

PYRAMIDS Scientists are able to use computers to study cross sections of ancient artifacts and structures. Determine the shape of each cross section of the pyramid below.

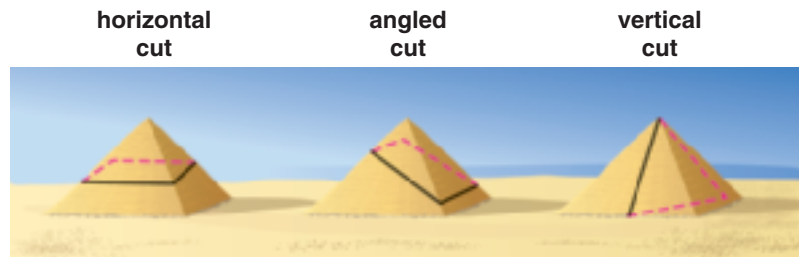

The horizontal cross section is a square. The angled cross section is a trapezoid. The vertical cross section is a triangle.

Guided Practice

3. **CAKES** Ramona has a cake pan shaped like half of a sphere, as shown at the right. Describe the shape of the cross sections of cakes baked in this pan if they are cut horizontally and vertically.



Torlo Labralage fotostock

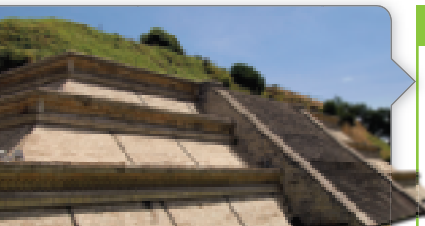

Real-WorldLink

The largest pyramid ever constructed is about 63 miles from Mexico City. It is 177 feet tall and its base covers an area of nearly 45 acres.

Source: Guinness World Records





Example 1 Use isometric dot paper to sketch each prism.

1. triangular prism 2 units high, with two sides of the base that are 5 units long and 4 units long
2. rectangular prism 2 units high, 3 units wide, and 5 units long

Example 2 Use isometric dot paper and each orthographic drawing to sketch a solid.

3.

4.

top view left view front view right view

- Example 3**
5. **FOOD** Describe how the cheese at the right can be sliced so that the slices form each shape.
 - a. rectangle
 - b. triangle
 - c. trapezoid

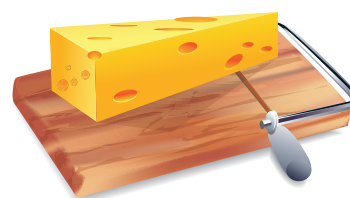

Describe each cross section.

6.

7.

Practice and Problem Solving

Extra Practice is on page R12.

Example 1 Use isometric dot paper to sketch each prism.

8. cube 3 units on each edge
9. triangular prism 4 units high, with two sides of the base that are 1 unit long and 3 units long
10. triangular prism 4 units high, with two sides of the base that are 2 units long and 6 units long

Example 2 Use isometric dot paper and each orthographic drawing to sketch a solid.

11.

12.

13.

14.

top view left view front view right view



Example 3

15 ART A piece of clay in the shape of a rectangular prism is cut in half as shown at the right.

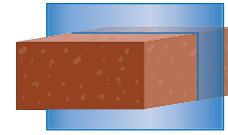

- a. Describe the shape of the cross section.
- b. Describe how the clay could be cut to make the cross section a triangle.

Describe each cross section.

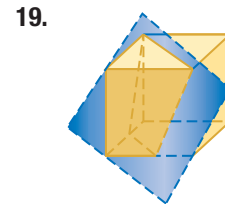
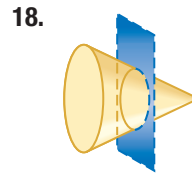
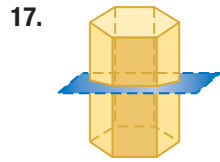
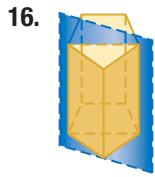

20. ARCHITECTURE Draw a top view, front view, and side view of the house at the right.

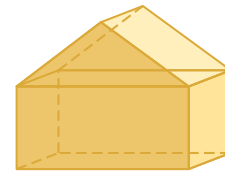

COOKIES Describe how to make a cut through a roll of cookie dough in the shape of a cylinder to make each shape.

21. circle
22. longest rectangle
23. oval
24. shorter rectangle

CCSS TOOLS Sketch the cross section from a vertical slice of each figure.

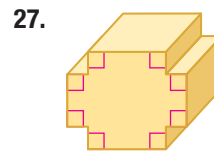
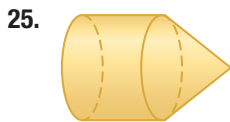

28. EARTH SCIENCE Crystals are solids in which the atoms are arranged in regular geometrical patterns. Sketch a cross section from a horizontal slice of each crystal. Then describe the rotational symmetry about the vertical axis.

a. tetragonal



b. hexagonal



c. monoclinic

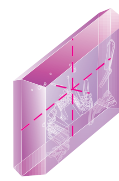

29. ART In a *perspective drawing*, a *vanishing point* is used to make the two-dimensional drawing appear three-dimensional. From one vanishing point, objects can be drawn from different points of view, as shown at the right.

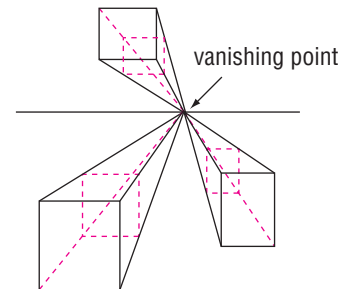

- a. Draw a horizontal line and a vanishing point on the line. Draw a rectangle somewhere above the line and use the vanishing point to make a perspective drawing.
- b. On the same drawing, draw a rectangle somewhere below the line and use the vanishing point to make a perspective drawing.
- c. Describe the different views of the two drawings.

Draw the top, left, front, and right view of each solid.

30.

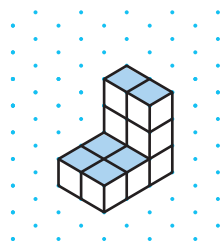

31.

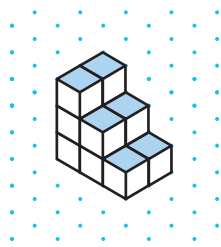

32.

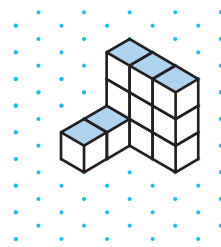

33. The top, front, and right views of a three-dimensional figure are shown at the right.

a. Make a sketch of the solid.

b. Describe two different ways that a rectangular cross section can be made.

c. Make a connection between the front and right views of the solid and cross sections of the solid.

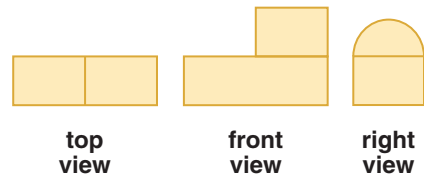

34. **MULTIPLE REPRESENTATIONS** In this problem, you will investigate isometric drawings.

a. **Geometric** Create isometric drawings of three different solids.

b. **Tabular** Create a table that includes the number of cubes needed to construct the solid and the number of squares visible in the isometric drawing.

c. **Verbal** Is there a correlation between the number of cubes needed to construct a solid and the number of squares visible in the isometric drawing? Explain.

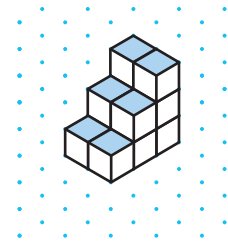

H.O.T. Problems Use Higher-Order Thinking Skills

35. **CHALLENGE** The figure at the right is a cross section of a geometric solid. Describe a solid and how the cross section was made.



36. **CCSS ARGUMENTS** Determine whether the following statement is *true* or *false*. Explain your reasoning.

If the left, right, front, and back orthographic views of two objects are the same, then the objects are the same figure.

37. **OPEN ENDED** Use isometric dot paper to draw a solid consisting of 12 cubic units. Then sketch the orthographic drawing for your solid.

38. **CHALLENGE** Draw the top view, front view, and left view of the solid figure at the right.

39. **WRITING IN MATH** A hexagonal pyramid is sliced through the vertex and the base so that the prism is separated into two congruent parts. Describe the cross section. Is there more than one way to separate the figure into two congruent parts? Will the shape of the cross section change? Explain.

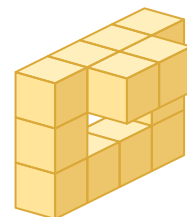

Standardized Test Practice

40. Which polyhedron is represented by the net shown below?

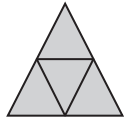

- A cube
B octahedron
C triangular prism
D triangular pyramid

41. **EXTENDED RESPONSE** A homeowner wants to build a 3-foot-wide deck around his circular pool as shown below.

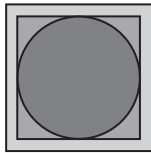

- a. Find the outer perimeter of the deck to the nearest foot, if the circumference of the pool is about 81.64 feet.
b. What is the area of the top of the deck?

42. **ALGEBRA** Which inequality *best* describes the graph shown below?

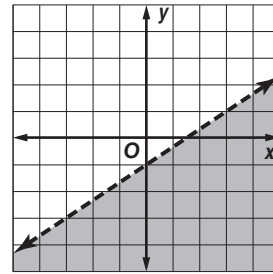

- F $y < \frac{2}{3}x - 1$
G $y \leq \frac{2}{3}x - 1$
H $y > \frac{2}{3}x - 1$
J $y \geq \frac{2}{3}x - 1$

43. **SAT/ACT** Expand $(4\sqrt{5})^2$.

- A 20
B $8\sqrt{5}$
C $16\sqrt{5}$
D 40
E 80

Spiral Review

For each pair of similar figures, use the given areas to find the scale factor from the blue to the green figure. Then find x . (Lesson 11-5)

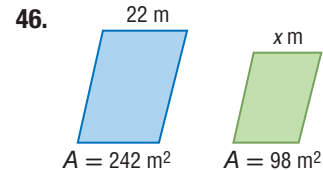
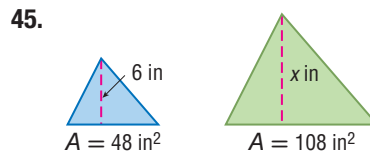
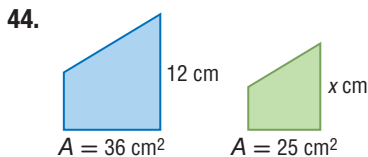

47. **FURNITURE DESIGN** Jenna wants to cover the cushions of her papasan chair with new fabric. There are seven congruent circular cushions with a diameter of 12 inches around a center cushion with a diameter of 20 inches. Find the area of fabric in square yards that she will need to cover both sides of the cushions. Allow an extra 3 inches of fabric around each cushion. (Lesson 11-4)



Skills Review

Find the perimeter or circumference and area of each figure. Round to the nearest tenth.

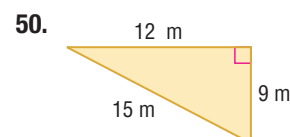
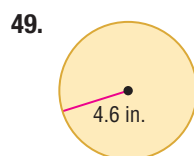
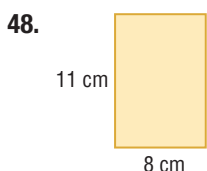

Geometry Lab Topographic Maps



Maps are representations of Earth or some part of Earth. **Topographic maps** are representations of the three-dimensional surface of Earth on a two-dimensional piece of paper. In a topographic map, the *topography*, or shape of Earth's surface, is illustrated through the use of *contours*, which are imaginary lines that join locations with the same elevation.

Some topographic maps show more than contours. These maps may include symbols that represent vegetation, rivers, and other landforms, as well as streets and buildings.

Follow these steps to read a topographic map.

- Thin lines represent contours. Since each contour is a line of equal elevation, they never cross. The closer together the contour lines, the steeper the slope.
- Contour lines form V shapes in valleys or riverbeds. The Vs point uphill.
- Most often, closed loops indicate that the surface slopes uphill on the inside and downhill on the outside. The innermost loop is the highest area.
- Pay attention to the colors. Blue represents water; green represents vegetation; red represents urban areas; black represents roads, trails, and railroads.
- The scale on a 1:24,000 map indicates that 1 inch equals 2000 feet.

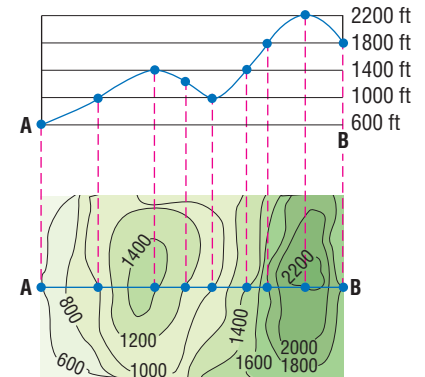

Explore the Model

Use the topographic map above to answer these questions.

1. According to the scale, what is the vertical distance between each contour line?
2. What is the difference in height between the lowest and highest points?
3. What do you notice about the contour lines for the peaks of the hills?
4. Describe a steep slope on the topographic map. How do you know it is steep?
5. Explain how you would draw a topographic map given a side view of some hills.

Model and Analyze

6. Draw a topographic map similar to the map below for the side view of the hills from points A to B.
7. Draw a possible side view similar to the map below from points A to B of the hills from the topographic map. Measures are given in feet.

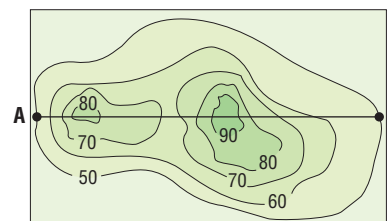
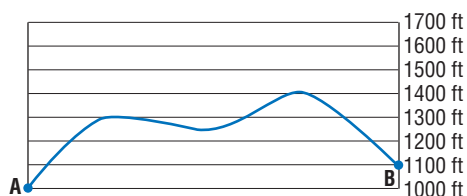

Surface Areas of Prisms and Cylinders

Then

- You found areas of polygons.

Now

- Find lateral areas and surface areas of prisms.
- Find lateral areas and surface areas of cylinders.

Why?

- Atlanta's Georgia Aquarium is the largest aquarium in the world, with more than 8 million gallons of water and more than 500 species from around the world. The aquarium has an underwater tunnel that is 100 feet long with 4574 square feet of viewing windows.



New Vocabulary

- lateral face
- lateral edge
- base edge
- altitude
- height
- lateral area
- axis
- composite solid



Common Core State Standards

Content Standards
G.MG.3 Apply geometric methods to solve problems (e.g., designing an object or structure to satisfy physical constraints or minimize cost; working with typographic grid systems based on ratios). ★

Mathematical Practices

- Make sense of problems and persevere in solving them.
- Attend to precision.

1 Lateral Areas and Surface Areas of Prisms In a solid figure, faces that are not bases are called **lateral faces**. Lateral faces intersect each other at the **lateral edges**, which are all parallel and congruent. The lateral faces intersect the base at the **base edges**. The **altitude** is a perpendicular segment that joins the planes of the bases. The **height** is the length of the altitude.

Recall that a prism is a polyhedron with two parallel congruent bases. In a right prism, the lateral edges are altitudes and the lateral faces are rectangles. In an oblique prism, the lateral edges are not perpendicular to the bases. At least one lateral face is not a rectangle.

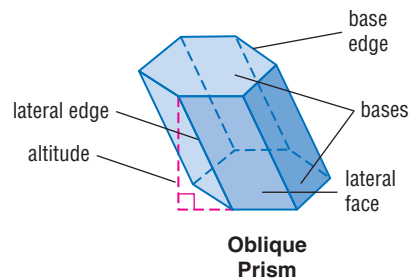
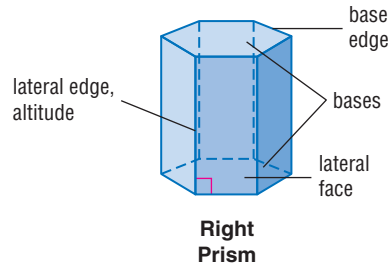

The **lateral area** L of a prism is the sum of the areas of the lateral faces. The net at the right shows how to find the lateral area of a prism.

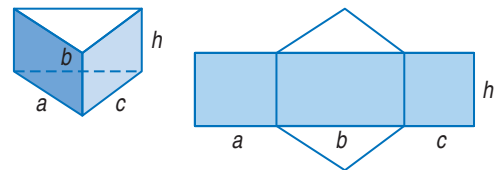

$$\begin{aligned}
 L &= a(h) + b(h) + c(h) && \text{Sum of areas of lateral faces} \\
 &= (a + b + c)h && \text{Distributive Property} \\
 &= Ph && P = a + b + c
 \end{aligned}$$

Key Concept Lateral Area of a Prism

Words The lateral area L of a right prism is $L = Ph$, where h is the height of the prism and P is the perimeter of a base.

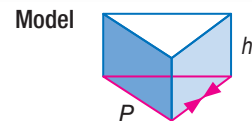

Symbols $L = Ph$

From this point on, you can assume that solids in the text are right solids. If a solid is oblique, it will be clearly stated.





Example 1 Lateral Area of a Prism

WatchOut!

Right Prisms The bases of a right prism are congruent, but the faces are not always congruent.

Find the lateral area of the prism. Round to the nearest tenth.

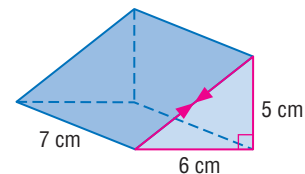

Step 1 Find the missing side length of the base.

$$c^2 = 6^2 + 5^2$$

Pythagorean Theorem

$$c^2 = 61$$

Simplify.

$$c \approx 7.8$$

Take the positive square root of each side.

Step 2 Find the lateral area.

$$L = Ph$$

Lateral area of a prism

$$\approx (5 + 6 + 7.8)7$$

Substitution

$$\approx 131.6$$

Simplify.

The lateral area is about 131.6 square centimeters.

GuidedPractice

1. The length of each side of the base of a regular octagonal prism is 6 inches, and the height is 11 inches. Find the lateral area.

The surface area of a prism is the sum of the lateral area and the areas of the bases.

KeyConcept Surface Area of a Prism

Words The surface area S of a right prism is $S = L + 2B$, where L is its lateral area and B is the area of a base.

Model

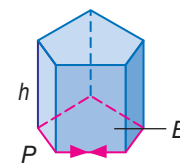

Symbols $S = L + 2B$ or $S = Ph + 2B$



Example 2 Surface Area of a Prism

Find the surface area of the rectangular prism.

Use the 9-foot by 4-foot rectangle as the base.

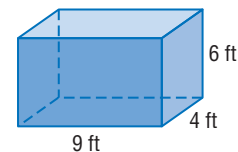

$$S = Ph + 2B$$

Surface area of a prism

$$= (2 \cdot 9 + 2 \cdot 4)(6) + 2(9 \cdot 4)$$

Substitution

$$= 228$$

Simplify.

The surface area of the prism is 228 square feet.

GuidedPractice

2. Find the surface area of the triangular prism. Round to the nearest tenth.

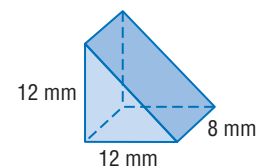

StudyTip

CCSS Perseverance In Example 2, you can also use a 6-foot by 4-foot rectangle as the base. The height would be 9 feet. While choosing a different base does not affect the surface area, it will change the lateral area.



2 Lateral Areas and Surface Areas of Cylinders The **axis** of a cylinder is the segment with endpoints that are centers of the circular bases. If the axis is also an altitude, then the cylinder is a right cylinder. If the axis is not an altitude, then the cylinder is an oblique cylinder.

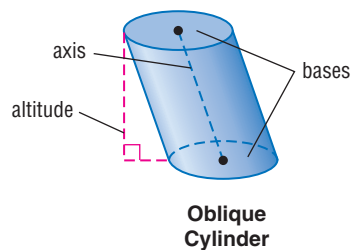
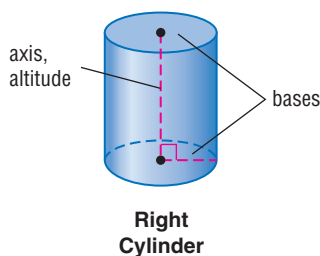

The lateral area of a right cylinder is the area of the curved surface. Like a right prism, the lateral area L equals Ph . Since the base is a circle, the perimeter is the circumference of the circle C . So, the lateral area is Ch or $2\pi rh$.

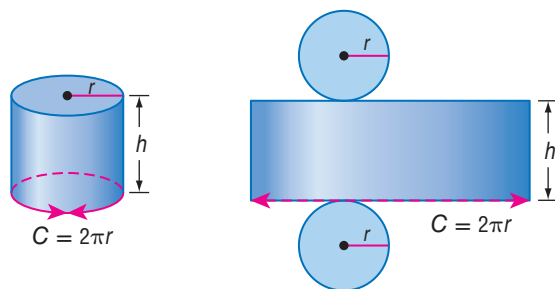

StudyTip

Formulas An alternate formula for the lateral area of a cylinder is $L = \pi dh$, with πd as the circumference of a circle.

The surface area of a cylinder is the lateral area plus the areas of the bases.

KeyConcept Surface Area of a Cylinder

Words The lateral area L of a right cylinder is $L = 2\pi rh$, where r is the radius of a base and h is the height.

The surface area S of a right cylinder is $S = 2\pi rh + 2\pi r^2$, where r is the radius of a base and h is the height.

Symbols $L = 2\pi rh$
 $S = L + 2B$ or $2\pi rh + 2\pi r^2$

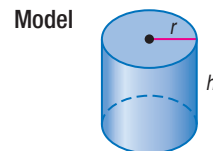

Example 3 Lateral Area and Surface Area of a Cylinder

Find the lateral area and the surface area of the cylinder. Round to the nearest tenth.

$L = 2\pi rh$	Lateral area of a cylinder
$= 2\pi(7.5)(18)$	Replace r with 7.5 and h with 18.
≈ 848.2	Use a calculator.
$S = 2\pi rh + 2\pi r^2$	Surface area of a cylinder
$\approx 848.2 + 2\pi(7.5)^2$	Replace $2\pi rh$ with 848.2 and r with 7.5.
≈ 1201.6	Use a calculator.

The lateral area is about 848.2 square millimeters, and the surface area is about 1201.6 square millimeters.

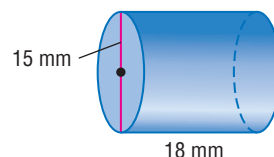

StudyTip

Estimation Before finding the lateral area of a cylinder, use mental math to estimate. To estimate, multiply the diameter by 3 (to approximate π) and then by the height of the cylinder.

GuidedPractice

3A. $r = 5$ in., $h = 9$ in.

3B. $d = 6$ cm, $h = 4.8$ cm

Real-World Example 4 Find Missing Dimensions

CRAFTS Sheree used the rectangular piece of felt shown at the right to cover the curved surface of her cylindrical pencil holder. What is the radius of the pencil holder?

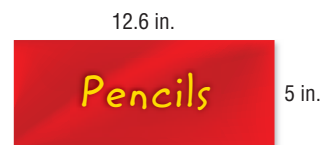

$L = 2\pi rh$ Lateral area of a cylinder

$63 = 2\pi r(5)$ Replace L with $12.6 \cdot 5$ or 63 and h with 5 .

$63 = 10\pi r$ Simplify.

$2.0 \approx r$ Divide each side by 10π .

The radius of the pencil holder is about 2 inches.

Guided Practice

- Find the diameter of a base of a cylinder if the surface area is 464π square centimeters and the height is 21 centimeters.

Check Your Understanding

= Step-by-Step Solutions begin on page R14.



Example 1

- Find the lateral area of the prism.

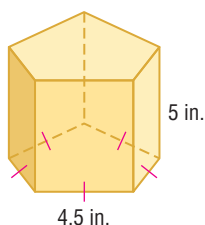

Examples 1–2 Find the lateral area and surface area of each prism.

2.

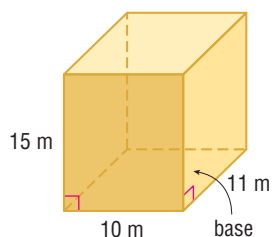

3.

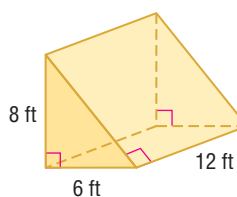

Example 3

- CARS** Evan is buying new tire rims that are 14 inches in diameter and 6 inches wide. Determine the lateral area of each rim. Round to the nearest tenth.

Find the lateral area and surface area of each cylinder. Round to the nearest tenth.

5.

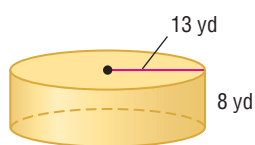

6.

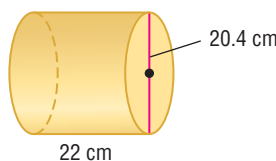

Example 4

- FOOD** The can of soup at the right has a surface area of 286.3 square centimeters. What is the height of the can? Round to the nearest tenth.
- The surface area of a cube is 294 square inches. Find the length of a lateral edge.

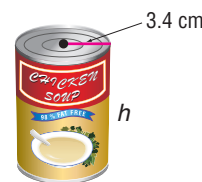

Examples 1–2 Find the lateral area and surface area of each prism. Round to the nearest tenth if necessary.

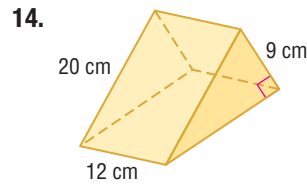
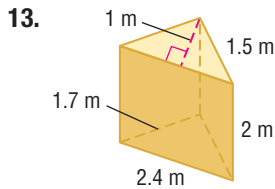
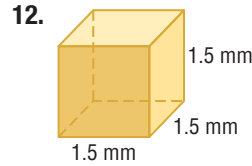
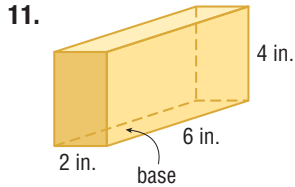
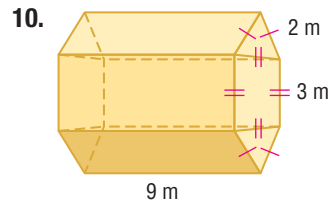
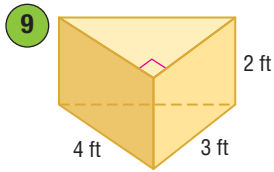

15. rectangular prism: $\ell = 25$ centimeters, $w = 18$ centimeters, $h = 12$ centimeters

16. triangular prism: $h = 6$ inches, right triangle base with legs 9 inches and 12 inches

Examples 1–3 CEREAL Find the lateral area and the surface area of each cereal container. Round to the nearest tenth if necessary.

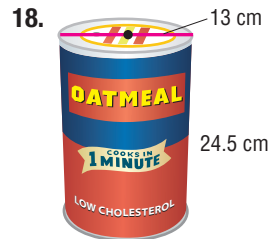

Example 3 **SENSE-MAKING** Find the lateral area and surface area of each cylinder. Round to the nearest tenth.

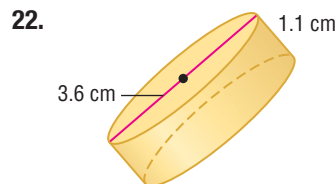
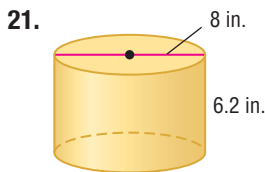
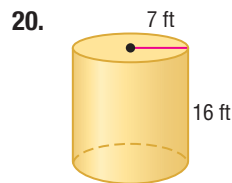
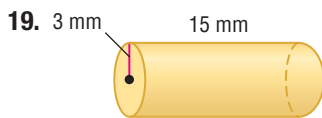

23. **WORLD RECORDS** The largest beverage can was a cylinder with height 4.67 meters and diameter 2.32 meters. What was the surface area of the can to the nearest tenth?



Example 4

Use the given lateral area and the diagram to find the missing measure of each solid. Round to the nearest tenth if necessary.

24. $L = 48 \text{ in}^2$

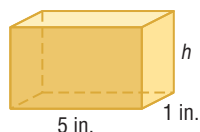

25. $L \approx 635.9 \text{ cm}^2$

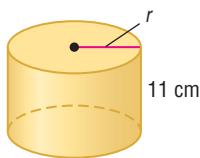

26. A right rectangular prism has a surface area of 1020 square inches, a length of 6 inches, and a width of 9 inches. Find the height.

27. A cylinder has a surface area of 256π square millimeters and a height of 8 millimeters. Find the diameter.

28. **MONUMENTS** A *monolith* mysteriously appeared overnight at Seattle, Washington's Manguson Park. A hollow rectangular prism, the monolith was 9 feet tall, 4 feet wide, and 1 foot deep.

- a. Find the area in square feet of the structure's surfaces that lie above the ground.
- b. Use dimensional analysis to find the area in square yards.

29. **ENTERTAINMENT** The graphic shows the results of a survey in which people were asked where they like to watch movies.

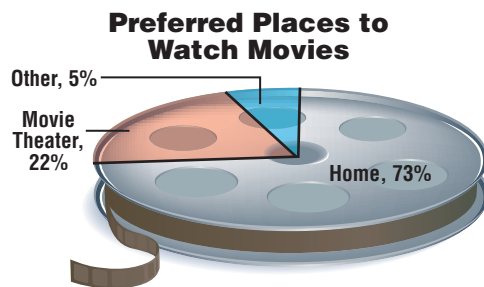

- a. Suppose the film can is a cylinder 12 inches in diameter. Explain how to find the surface area of the portion that represents people who prefer to watch movies at home.
- b. If the film can is 3 inches tall, find the surface area of the portion in part a.

CCSS SENSE-MAKING Find the lateral area and surface area of each oblique solid. Round to the nearest tenth.

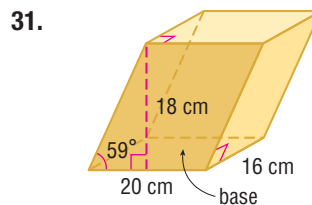
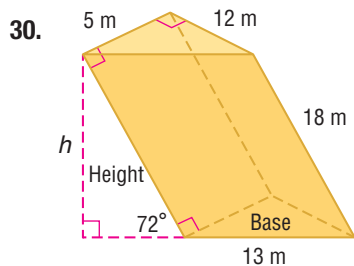

32. **LAMPS** The lamp shade is a cylinder of height 18 inches with a diameter of $6\frac{3}{4}$ inches.

- a. What is the lateral area of the shade to the nearest tenth?
- b. How does the lateral area change if the height is divided by 2?



33. Find the approximate surface area of a right hexagonal prism if the height is 9 centimeters and each base edge is 4 centimeters. (*Hint*: First, find the length of the apothem of the base.)



34. **DESIGN** A mailer needs to hold a poster that is almost 38 inches long and has a maximum rolled diameter of 6 inches.
- Design a mailer that is a triangular prism. Sketch the mailer and its net.
 - Suppose you want to minimize the surface area of the mailer. What would be the dimensions of the mailer and its surface area?

A **composite solid** is a three-dimensional figure that is composed of simpler figures. Find the surface area of each composite solid. Round to the nearest tenth if necessary.

35.

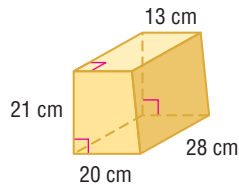

36.

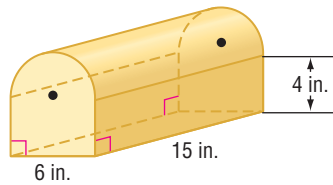

37.

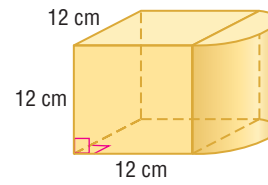

38. **MULTIPLE REPRESENTATIONS** In this problem, you will investigate the lateral area and surface area of a cylinder.
- Geometric** Sketch cylinder *A* with a radius of 3 centimeters and a height of 5 centimeters, cylinder *B* with a radius of 6 centimeters and a height of 5 centimeters, and cylinder *C* with a radius of 3 centimeters and a height of 10 centimeters.
 - Tabular** Create a table of the radius, height, lateral area, and surface area of cylinders *A*, *B*, and *C*. Write the areas in terms of π .
 - Verbal** If the radius is doubled, what effect does it have on the lateral area and the surface area of a cylinder? If the height is doubled, what effect does it have on the lateral area and the surface area of a cylinder?

H.O.T. Problems Use Higher-Order Thinking Skills

39. **ERROR ANALYSIS** Montell and Derek are finding the surface area of a cylinder with height 5 centimeters and radius 6 centimeters. Is either of them correct? Explain.

Montell

$$\begin{aligned} S &= \pi(6)^2 + \pi(6)(5) \\ &= 36\pi + 30\pi \\ &= 66\pi \text{ cm}^2 \end{aligned}$$

Derek

$$\begin{aligned} S &= 2\pi(6)^2 + 2\pi(6)(5) \\ &= 72\pi + 60\pi \\ &= 132\pi \text{ cm}^2 \end{aligned}$$

40. **WRITING IN MATH** Sketch an oblique rectangular prism, and describe the shapes that would be included in a net for the prism. Explain how the net is different from that of a right rectangular prism.
41. **CCSS PRECISION** Compare and contrast finding the surface area of a prism and finding the surface area of a cylinder.
42. **OPEN ENDED** Give an example of two cylinders that have the same lateral area and different surface areas. Describe the lateral area and surface areas of each.
43. **CHALLENGE** A right prism has a height of h units and a base that is an equilateral triangle of side ℓ units. Find the general formula for the total surface area of the prism. Explain your reasoning.
44. **WRITING IN MATH** A square based prism and a triangular prism are the same height. The base of the triangular prism is an equilateral triangle, with an altitude equal in length to the side of the square. Compare the lateral areas of the prisms.



Standardized Test Practice

45. If the surface area of the right rectangular prism is 310 square centimeters, what is the measure of the height h of the prism?

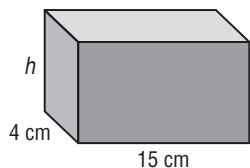

- A 5 cm C 10
 B $5\frac{1}{6}$ cm D $13\frac{3}{9}$ cm
46. **SHORT RESPONSE** A cylinder has a circumference of 16π inches and a height of 20 inches. What is the surface area of the cylinder in terms of π ?
47. Parker Flooring charges the following to install a hardwood floor in a new home.
 Subflooring: \$2.25 per square foot
 Wood flooring: \$4.59 per square foot
 Baseboards: \$1.95 per linear foot around room
 Nail & other materials: \$25.95 per job
 Labor: \$99 plus \$0.99 square foot
 What is the cost to install hardwood flooring in a room that is 18 by 15 feet?
 F \$2169.75 H \$2367.75
 G \$2268.75 J \$2765.55
48. **SAT/ACT** What is the value of $f(-2)$ if $f(x) = x^3 + 4x^2 - 2x - 3$?
 A -31 D 25
 B $-\frac{9}{2}$ E 28
 C 9

Spiral Review

Use isometric dot paper to sketch each prism. (Lesson 12-1)

49. rectangular prism 2 units high, 3 units long, and 2 units wide
 50. triangular prism 2 units high with bases that are right triangles with legs 3 units and 4 units long
 51. **BAKING** A bakery sells single-layer mini-cakes that are 3 inches in diameter for \$4 each. They also have a cake with the same thickness and a 9-inch diameter for \$15. Compare the areas of the cake tops to determine, which option is a better buy, nine mini-cakes or one 9-inch cake. Explain. (Lesson 11-5)

The diameters of $\odot R$, $\odot S$, and $\odot T$ are 10 inches, 14 inches, and 9 inches, respectively. Find each measure. (Lesson 10-1)

52. YX
 53. SY

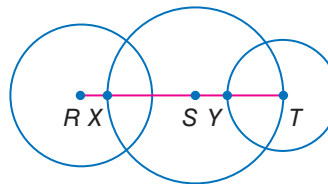

Skills Review

Find x . Round to the nearest tenth.

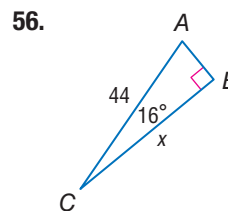
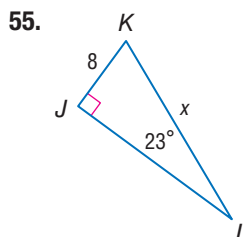
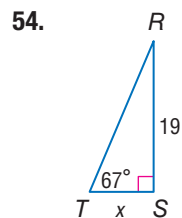

LESSON 12-3

Surface Areas of Pyramids and Cones

Then

- You found areas of regular polygons.

Now

- Find lateral areas and surface areas of pyramids.
- Find lateral areas and surface areas of cones.

Why?

- The Transamerica Pyramid in San Francisco, California, covers nearly one city block. Its unconventional design allows light and air to filter down to the streets around the building, unlike the more traditional rectangular prism skyscrapers.



New Vocabulary

- regular pyramid
- slant height
- right cone
- oblique cone



Common Core State Standards

Content Standards

G.MG.1 Use geometric shapes, their measures, and their properties to describe objects (e.g., modeling a tree trunk or a human torso as a cylinder). ★

Mathematical Practices

- 1 Make sense of problems and persevere in solving them.
- 6 Attend to precision.

1 Lateral Area and Surface Area of Pyramids The *lateral faces* of a pyramid intersect at a common point called the *vertex*. Two lateral faces intersect at a *lateral edge*. A lateral face and the base intersect at a *base edge*. The *altitude* is the segment from the vertex perpendicular to the base.

A **regular pyramid** has a base that is a regular polygon and the altitude has an endpoint at the center of the base. All the lateral edges are congruent and all the lateral faces are congruent isosceles triangles. The height of each lateral face is called the **slant height** ℓ of the pyramid.

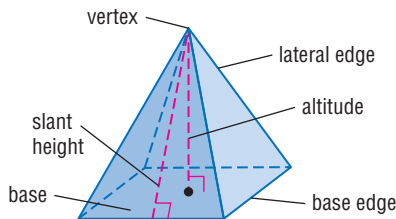

Regular Pyramid

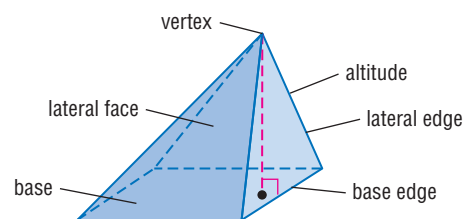

Nonregular Pyramid

The lateral area L of a regular pentagonal pyramid is the sum of the areas of all its congruent triangular faces as shown in the net at the right.

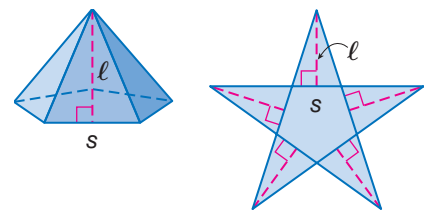

$$\begin{aligned}
 L &= \frac{1}{2}sl + \frac{1}{2}sl + \frac{1}{2}sl + \frac{1}{2}sl + \frac{1}{2}sl && \text{Sum of the areas of the lateral faces} \\
 &= \frac{1}{2}\ell(s + s + s + s + s) && \text{Distributive Property} \\
 &= \frac{1}{2}P\ell && P = s + s + s + s + s
 \end{aligned}$$

Key Concept Lateral Area of a Regular Pyramid

Words The lateral area L of a regular pyramid is $L = \frac{1}{2}P\ell$, where ℓ is the slant height and P is the perimeter of the base.

Model

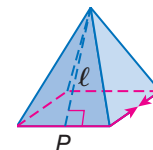

Symbols $L = \frac{1}{2}P\ell$





Example 1 Lateral Area of a Regular Pyramid

Find the lateral area of the square pyramid.

$$L = \frac{1}{2}P\ell$$

Lateral area of a regular pyramid

$$= \frac{1}{2}(16)(6) \text{ or } 48 \quad P = 4 \cdot 4 \text{ or } 16, \ell = 6$$

The lateral area is 48 square inches.

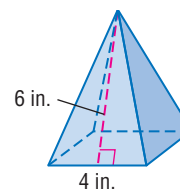

StudyTip

Alternative Method You can also find the lateral area of a pyramid by adding the areas of the congruent lateral faces. area of one face:

$$\frac{1}{2}(4)(6) = 12 \text{ in}^2$$

lateral area:
 $4 \cdot 12 = 48 \text{ in}^2$

GuidedPractice

1. Find the lateral area of a regular hexagonal pyramid with a base edge of 9 centimeters and a lateral height of 7 centimeters.

The surface area of a pyramid is the sum of the lateral area and the area of the base.

KeyConcept Surface Area of a Regular Pyramid

Words The surface area S of a regular pyramid is $S = \frac{1}{2}P\ell + B$, where P is the perimeter of the base, ℓ is the slant height, and B is the area of the base.

Model

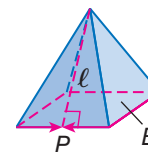

Symbols $S = \frac{1}{2}P\ell + B$



Example 2 Surface Area of a Square Pyramid

Find the surface area of the square pyramid to the nearest tenth.

Step 1 Find the slant height.

$$c^2 = a^2 + b^2 \quad \text{Pythagorean Theorem}$$

$$\ell^2 = 16^2 + 6^2 \quad a = 16, b = 6, \text{ and } c = \ell$$

$$\ell = \sqrt{292} \quad \text{Simplify.}$$

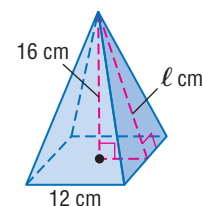

Step 2 Find the perimeter and area of the base.

$$P = 4 \cdot 12 \text{ or } 48 \text{ cm} \quad A = 12^2 \text{ or } 144 \text{ cm}^2$$

Step 3 Find the surface area of the pyramid.

$$S = \frac{1}{2}P\ell + B \quad \text{Surface area of a regular pyramid}$$

$$= \frac{1}{2}(48)\sqrt{292} + 144 \quad P = 48, \ell = \sqrt{292}, \text{ and } B = 144$$

$$\approx 554.1 \quad \text{Use a calculator.}$$

The surface area of the pyramid is about 554.1 square centimeters.

StudyTip

Making Connections The surface area of a pyramid equals $L + B$, not $L + 2B$, because a pyramid has only one base.

GuidedPractice

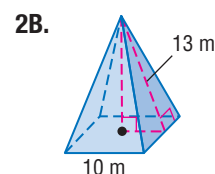
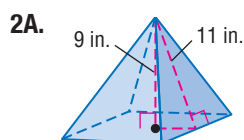

Example 3 Surface Area of a Regular Pyramid

Find the surface area of the regular pyramid. Round to the nearest tenth.

Step 1 Find the perimeter of the base.
 $P = 6 \cdot 5$ or 30 cm

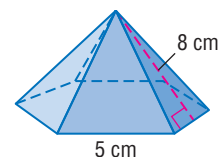

Step 2 Find the length of the apothem and the area of the base.

A central angle of the hexagon is $\frac{360^\circ}{6}$ or 60° , so the angle formed in the triangle at the right is 30° .

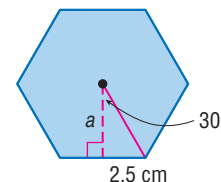

$$\begin{aligned} \tan 30^\circ &= \frac{2.5}{a} \\ a &= \frac{2.5}{\tan 30^\circ} \\ &\approx 4.3 \end{aligned}$$

Write a trigonometric ratio to find the apothem a .
Solve for a .

Use a calculator.

$$\begin{aligned} A &= \frac{1}{2}Pa \\ &\approx \frac{1}{2}(30)(4.3) \\ &\approx 64.5 \end{aligned}$$

Area of a regular polygon

Replace P with 30 and a with 4.3.

Multiply.

So, the area of the base B is approximately 64.5 square centimeters.

Step 3 Find the surface area of the pyramid.

$$\begin{aligned} S &= \frac{1}{2}P\ell + B \\ &= \frac{1}{2}(30)(8) + 64.5 \\ &\approx 184.5 \end{aligned}$$

Surface area of a regular pyramid

$P = 30$, $\ell = 8$, and $B \approx 64.5$

Simplify.

The surface area of the pyramid is about 184.5 square centimeters.

Review Vocabulary

Trigonometric Ratios

$$\begin{aligned} \sin A &= \frac{\text{opp}}{\text{hyp}} \\ \cos A &= \frac{\text{adj}}{\text{hyp}} \\ \tan A &= \frac{\text{opp}}{\text{adj}} \end{aligned}$$

Guided Practice

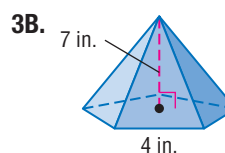
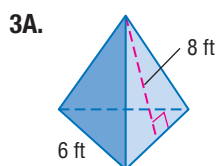

2 Lateral Area and Surface Area of Cones Recall that a cone has a circular base and a vertex. The axis of a cone is the segment with endpoints at the vertex and the center of the base. If the axis is also the altitude, then the cone is a **right cone**. If the axis is not the altitude, then the cone is an **oblique cone**.

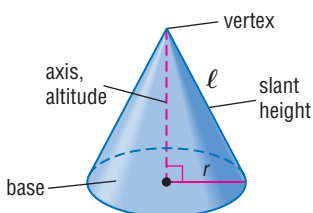

Right Cone

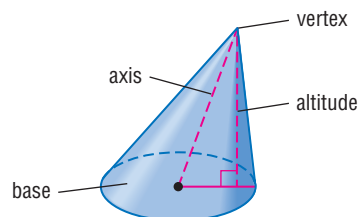

Oblique Cone

The net for a cone is shown at the right. The circle with radius r is the base of the cone. It has a circumference of $2\pi r$ and an area of πr^2 . The sector with radius ℓ is the lateral surface of the cone. Its arc measure is $2\pi r$. You can use a proportion to find its area.

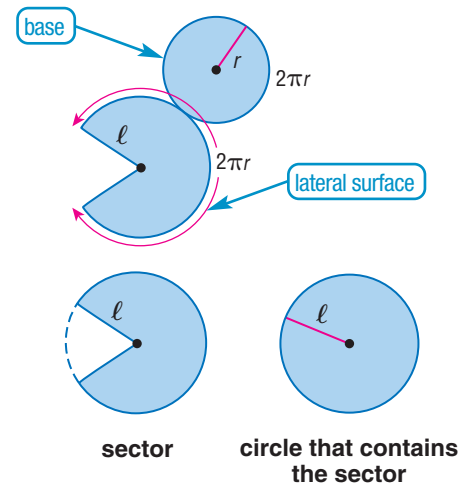

$$\frac{\text{area of sector}}{\text{area of circle}} = \frac{\text{measure of arc}}{\text{circumference of circle}}$$

$$\frac{\text{area of sector}}{\pi \ell^2} = \frac{2\pi r}{2\pi \ell}$$

$$\text{area of sector} = \pi \ell^2 \cdot \frac{2\pi r}{2\pi \ell} \text{ or } \pi r \ell$$

StudyTip

CCSS Sense-Making Like a pyramid, the lateral area of a right circular cone L equals $\frac{1}{2}P\ell$. Since the base is a circle, the perimeter is the circumference of the base C . So, the lateral area is $\frac{1}{2}C\ell$.

$$\begin{aligned} L &= \frac{1}{2}C\ell \\ &= \frac{1}{2}(2\pi r) \\ &= \pi r \ell \end{aligned}$$

KeyConcept Lateral and Surface Area of a Cone

Words

The lateral area L of a right circular cone is $L = \pi r \ell$, where r is the radius of the base and ℓ is the slant height.

The surface area S of a right circular cone is $S = \pi r \ell + \pi r^2$, where r is the radius of the base and ℓ is the slant height.

Symbols

$$L = \pi r \ell \quad S = \pi r \ell + \pi r^2$$

Model

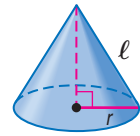

Real-World Example 4 Lateral Area of a Cone

ARCHITECTURE The conical slate roof at the right has a height of 16 feet and a radius of 12 feet. Find the lateral area.

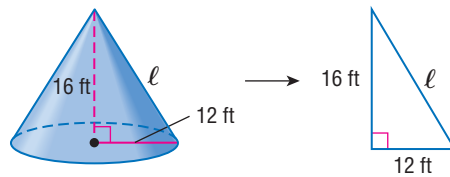

StudyTip

Draw a Diagram When solving word problems involving solids, it is helpful to draw a figure and label the known parts. Use a variable to label the measure or measures that you need to find.

Step 1 Find the slant height ℓ .

$$\ell^2 = 16^2 + 12^2 \quad \text{Pythagorean Theorem}$$

$$\ell^2 = 400 \quad \text{Simplify.}$$

$$\ell = 20 \quad \text{Take the positive square root of each side.}$$

Step 2 Find the lateral area L .

$$\text{Estimate } L \approx 3 \cdot 12 \cdot 20 \text{ or } 720 \text{ ft}^2$$

$$L = \pi r \ell \quad \text{Lateral area of a cone}$$

$$= \pi(12)(20) \quad r = 12 \text{ and } \ell = 20$$

$$\approx 754 \quad \text{Use a calculator.}$$

The lateral area of the conical roof is about 754 square feet. The answer is reasonable compared to the estimate.

GuidedPractice

4. **ICE CREAM** A waffle cone is $5\frac{1}{2}$ inches tall and the diameter of the base is $2\frac{1}{2}$ inches. Find the lateral area of the cone. Round to the nearest tenth.



Example 5 Surface Area of a Cone

Find the surface area of a cone with a diameter of 14.8 centimeters and a slant height of 15 centimeters.

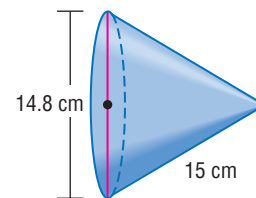

Estimate: $S \approx 3 \cdot 7 \cdot 20 + 3 \cdot 50$ or 570 cm^2

$$S = \pi r \ell + \pi r^2 \quad \text{Surface area of a cone}$$

$$= \pi(7.4)(15) + \pi(7.4)^2 \quad r = 7.4 \text{ and } \ell = 15$$

$$\approx 520.8 \quad \text{Use a calculator.}$$

The surface area of the cone is about 520.8 square centimeters. This is close to the estimate, so the answer is reasonable.

Guided Practice

Find the surface area of each cone. Round to the nearest tenth.

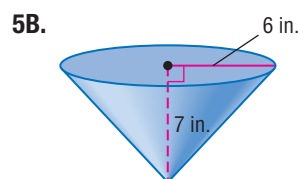
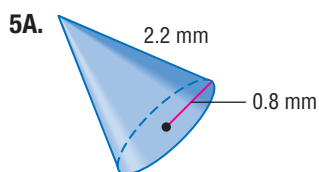

The formulas for lateral and surface area are summarized below.

Concept Summary Lateral and Surface Areas of Solids

WatchOut!

Bases The bases of right prisms and right pyramids are not always regular polygons.

Solid	Model	Lateral Area	Surface Area
prism		$L = Ph$	$S = L + 2B$ or $S = Ph + 2B$
cylinder		$L = 2\pi rh$	$S = L + 2B$ or $S = 2\pi rh + 2\pi r^2$
pyramid		$L = \frac{1}{2}P\ell$	$S = \frac{1}{2}P\ell + B$
cone		$L = \pi r \ell$	$S = \pi r \ell + \pi r^2$





Examples 1–3 Find the lateral area and surface area of each regular pyramid. Round to the nearest tenth if necessary.

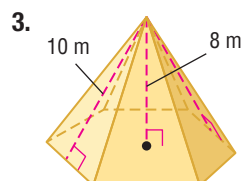
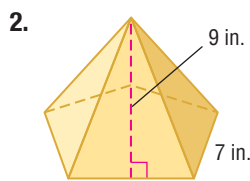
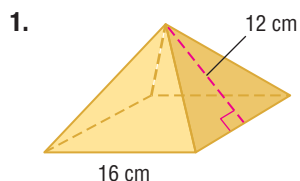

Examples 4–5 4. **TENTS** A conical tent is shown at the right. Round answers to the nearest tenth.

- Find the lateral area of the tent and describe what it represents.
- Find the surface area of the tent and describe what it represents.

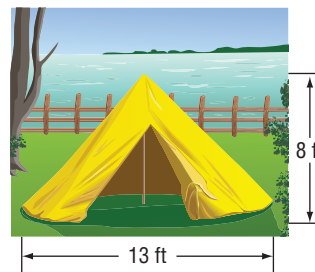

CGSS SENSE-MAKING Find the lateral area and surface area of each cone. Round to the nearest tenth.

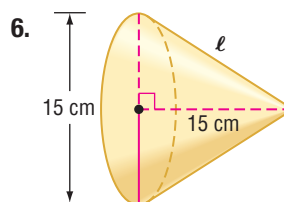
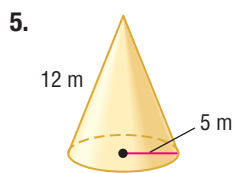

Practice and Problem Solving

Extra Practice is on page R12.

Examples 1–3 Find the lateral area and surface area of each regular pyramid. Round to the nearest tenth if necessary.

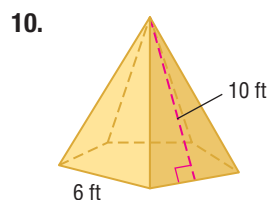
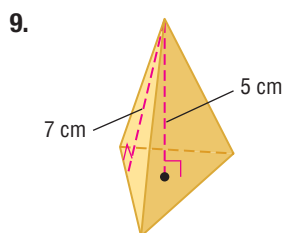
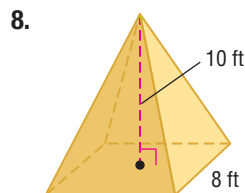
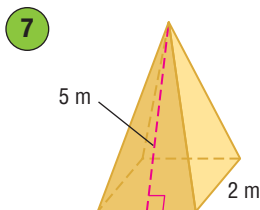

- square pyramid with an altitude of 12 inches and a slant height of 18 inches
- hexagonal pyramid with a base edge of 6 millimeters and a slant height of 9 millimeters
- ARCHITECTURE** Find the lateral area of a pyramid-shaped building that has a slant height of 210 feet and a square base 332 feet by 332 feet.



Examples 4–5 Find the lateral area and surface area of each cone. Round to the nearest tenth.

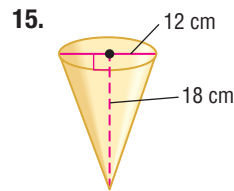
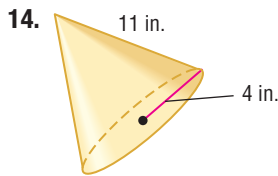

16. The diameter is 3.4 centimeters, and the slant height is 6.5 centimeters.
17. The altitude is 5 feet, and the slant height is $9\frac{1}{2}$ feet.
18. **MOUNTAINS** A conical mountain has a radius of 1.6 kilometers and a height of 0.5 kilometer. What is the lateral area of the mountain?
19. **HISTORY** Archaeologists recently discovered a 1500-year-old pyramid in Mexico City. The square pyramid measures 165 yards on each side and once stood 20 yards tall. What was the original lateral area of the pyramid?
20. Describe two polyhedrons that have 7 faces.
21. What is the sum of the number of faces, vertices, and edges of an octagonal pyramid?
22. **TEPEES** The dimensions of two canvas tepees are shown in the table at the right. Not including the floors, approximately how much more canvas is used to make Tepee B than Tepee A?
- | Tepee | Diameter (ft) | Height (ft) |
|-------|---------------|-------------|
| A | 14 | 6 |
| B | 20 | 9 |
23. The surface area of a square pyramid is 24 square millimeters and the base area is 4 square millimeters. What is the slant height of the pyramid?
24. The surface area of a cone is 18π square inches and the radius of the base is 3 inches. What is the slant height of the cone?
25. The surface area of a triangular pyramid is 532 square centimeters, and the base is 24 centimeters wide with a hypotenuse of 25 centimeters. What is the slant height of the pyramid?
26. Find the lateral area of the tent to the nearest tenth.
27. Find the surface area of the tank. Write in terms of π .

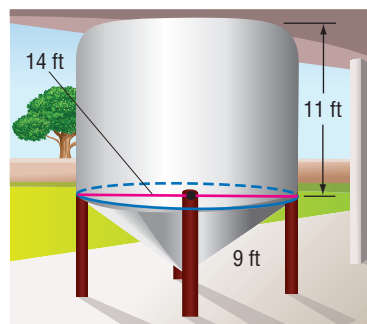
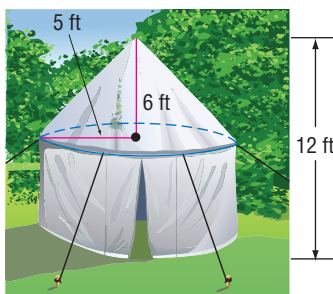

28. **CHANGING DIMENSIONS** A cone has a radius of 6 centimeters and a slant height of 12 centimeters. Describe how each change affects the surface area of the cone.
- The radius and the slant height are doubled.
 - The radius and the slant height are divided by 3.
29. **CCSS TOOLS** A solid has the net shown at the right.
- Describe the solid.
 - Make a sketch of the solid.

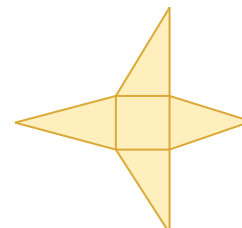

Sketch each solid and a net that represents the solid.

30. hexagonal pyramid

31. rectangular pyramid

32. **PETS** A *frustum* is the part of a solid that remains after the top portion has been cut by a plane parallel to the base. The ferret tent shown at the right is a frustum of a regular pyramid.



- Describe the faces of the solid.
- Find the lateral area and surface area of the frustum formed by the tent.
- Another pet tent is made by cutting the top half off of a pyramid with a height of 12 centimeters, slant height of 20 centimeters and square base with side lengths of 32 centimeters. Find the surface area of the frustum.

Find the lateral area and surface area of each solid. Round to the nearest tenth.

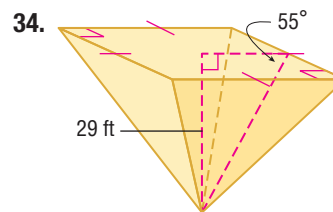
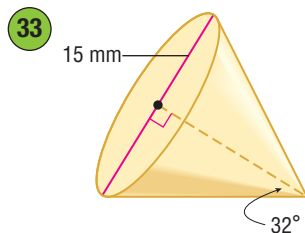

- MULTIPLE REPRESENTATIONS** In this problem, you will investigate the lateral and surface area of a square pyramid with a base edge of 3 units.
 - Geometric** Sketch the pyramid on isometric dot paper.
 - Tabular** Make a table showing the lateral areas of the pyramid for slant heights of 1, 3, and 9 units.
 - Verbal** Describe what happens to the lateral area of the pyramid if the slant height is tripled.
 - Analytical** Make a conjecture about how the lateral area of a square pyramid is affected if both the slant height and the base edge are tripled. Then test your conjecture.

H.O.T. Problems Use Higher-Order Thinking Skills

- WRITING IN MATH** Why does an oblique solid not have a slant height?
- REASONING** Classify the following statement as *sometimes*, *always*, or *never* true. Justify your reasoning.

The surface area of a cone of radius r and height h is less than the surface area of a cylinder of radius r and height h .
- REASONING** A cone and a square pyramid have the same surface area. If the areas of their bases are also equal, do they have the same slant height as well? Explain.
- OPEN ENDED** Describe a pyramid that has a total surface area of 100 square units.
- CCSS ARGUMENTS** Determine whether the following statement is *true* or *false*. Explain your reasoning.

A regular polygonal pyramid and a cone both have height h units and base perimeter P units. Therefore, they have the same total surface area.

- WRITING IN MATH** Describe how to find the surface area of a regular polygonal pyramid with an n -gon base, height h units, and an apothem of a units.



Standardized Test Practice

42. The top of a gazebo in a park is in the shape of a regular pentagonal pyramid. Each side of the pentagon is 10 feet long. If the slant height of the roof is about 6.9 feet, what is the lateral roof area?

A 34.5 ft^2 C 172.5 ft^2
 B 50 ft^2 D 250 ft^2

43. **SHORT RESPONSE** To the nearest square millimeter, what is the surface area of a cone with the dimensions shown?

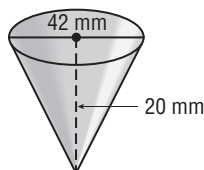

44. **ALGEBRA** Yu-Jun's craft store sells 3 handmade barrettes for \$9.99. Which expression can be used to find the total cost C of x barrettes?

F $C = \frac{9.99}{x}$ H $C = 3.33x$
 G $C = 9.99x$ J $C = \frac{x}{3.33}$

45. **SAT/ACT** What is the slope of a line perpendicular to the line with equation $2x + 3y = 9$?

A $-\frac{3}{2}$ D $\frac{3}{2}$
 B $-\frac{2}{3}$ E $\frac{9}{2}$
 C $\frac{2}{3}$

Spiral Review

46. Find the surface area of a cylinder with a diameter of 18 cm and a height of 12 cm. (Lesson 12-2)

Use isometric dot paper and each orthographic drawing to sketch a solid. (Lesson 12-1)

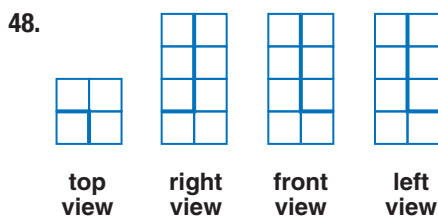
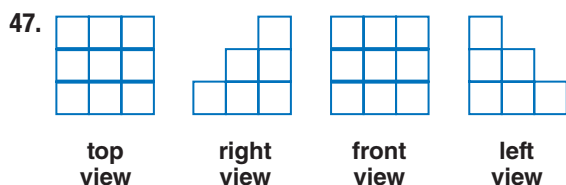

Graph each figure and its image in the given line. (Lesson 9-1)

$J(2, 4), K(4, 0), L(7, 3)$

$Q(4, 8), R(1, 6), S(2, 1), T(5, 5)$

$A(-2, 6), B(-2, 1), C(3, 1), D(3, 4)$

49. $\triangle JKL; x = 2$

51. $QRST; y = -1$

53. $ABCD; x = 1$

50. $\triangle JKL; y = 1$

52. $QRST; x = 4$

54. $ABCD; y = -2$

Skills Review

Find the perimeter and area of each parallelogram, triangle, or composite figure. Round to the nearest tenth.

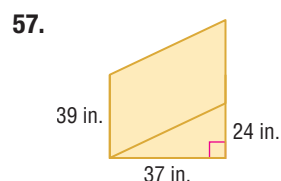
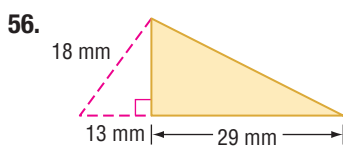
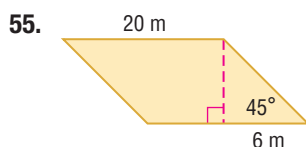



Then

- You found surface areas of prisms and cylinders.

Now

- 1 Find volumes of prisms.
- 2 Find volumes of cylinders.

Why?

- Planters come in a variety of shapes and sizes. You can approximate the amount of soil needed to fill a planter by finding the volume of the three-dimensional figure that it most resembles.



Common Core State Standards

Content Standards

G.GMD.1 Give an informal argument for the formulas for the circumference of a circle, area of a circle, volume of a cylinder, pyramid, and cone.

G.GMD.3 Use volume formulas for cylinders, pyramids, cones, and spheres to solve problems. ★

Mathematical Practices

- 1 Make sense of problems and persevere in solving them.
- 7 Look for and make use of structure.

1 Volume of Prisms Recall that the volume of a solid is the measure of the amount of space the solid encloses. Volume is measured in cubic units.

The rectangular prism at the right has $6 \cdot 4$ or 24 cubic units in the bottom layer. Since there are two layers, the total volume is $24 \cdot 2$ or 48 cubic units.

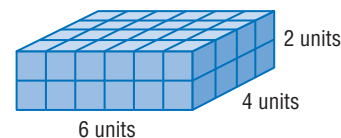

KeyConcept Volume of a Prism

Words The volume V of a prism is $V = Bh$, where B is the area of a base and h is the height of the prism.

Model

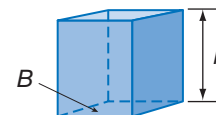

Symbols $V = Bh$



Example 1 Volume of a Prism

Find the volume of the prism.

Step 1 Find the area of the base B .

$$B = \frac{1}{2}bh \quad \text{Area of a triangle}$$

$$= \frac{1}{2}(12)(10) \text{ or } 60 \quad b = 12 \text{ and } h = 10$$

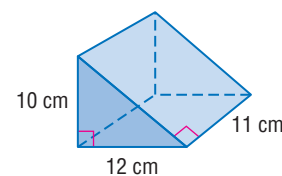

Step 2 Find the volume of the prism.

$$V = Bh \quad \text{Volume of a prism}$$

$$= 60(11) \text{ or } 660 \quad B = 60 \text{ and } h = 11$$

The volume of the prism is 660 cubic centimeters.

GuidedPractice

1A.

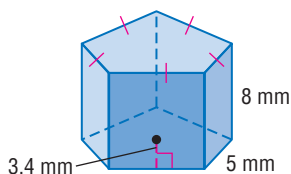

1B.

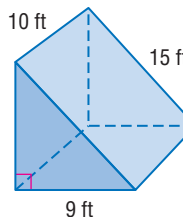



Real-World Career

Architectural Engineer

An architectural engineer applies the technical skills of engineering to the design, construction, operation, maintenance, and renovation of buildings.

Architectural engineers are required to have a bachelor's degree in engineering along with specialized coursework. Refer to Exercise 35.

2 Volume of Cylinders Like a prism, the volume of a cylinder can be thought of as consisting of layers. For a cylinder, these layers are congruent circular discs, similar to the coins in the roll shown. If we interpret the area of the base as the volume of a one-unit-high layer and the height of the cylinder as the number of layers, then the volume of the cylinder is equal to the volume of a layer times the number of layers or the area of the base times the height.

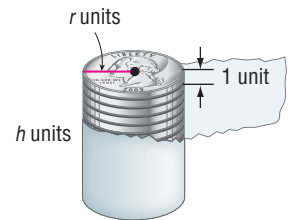

Key Concept Volume of a Cylinder

Words The volume V of a cylinder is $V = Bh$ or $V = \pi r^2 h$, where B is the area of the base, h is the height of the cylinder, and r is the radius of the base.

Model

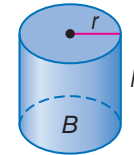

Symbols $V = Bh$ or $V = \pi r^2 h$



Example 2 Volume of a Cylinder

Find the volume of the cylinder at the right.

Estimate: $V \approx 3 \cdot 5^2 \cdot 5$ or 375 in^3

$$\begin{aligned} V &= \pi r^2 h && \text{Volume of a cylinder} \\ &= \pi(4.5)^2(5) && r = 4.5 \text{ and } h = 5 \\ &\approx 318.1 && \text{Use a calculator.} \end{aligned}$$

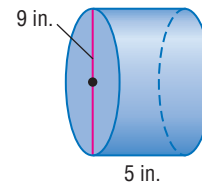

The volume of the cylinder is about 318.1 cubic inches. This is fairly close to the estimate, so the answer is reasonable.

Guided Practice

- Find the volume of a cylinder with a radius of 3 centimeters and a height of 8 centimeters. Round to the nearest tenth.

The first group of books at the right represents a right prism. The second group represents an oblique prism. Both groups have the same number of books. If all the books are the same size, then the volume of both groups is the same.

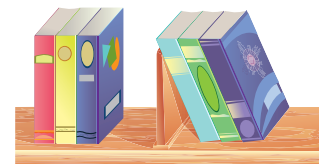

This demonstrates the following principle, which applies to all solids.

Watch Out!

Cross-Sectional Area

For solids with the same height to have the same volume, their cross-sections must have the same area. The cross sections of the different solids do not have to be congruent polygons.

Key Concept Cavalieri's Principle

Words If two solids have the same height h and the same cross-sectional area B at every level, then they have the same volume.

Models

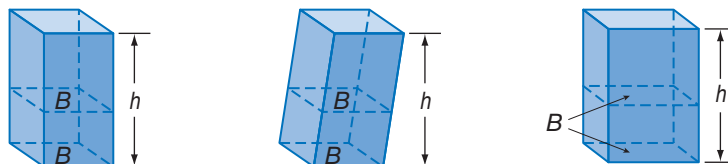

These prisms all have a volume of Bh .





Problem-Solving Tip

Make a Model When solving problems involving volume of solids, one way to help you visualize the problem is to make a model of the solid.

Example 3 Volume of an Oblique Solid

Find the volume of an oblique hexagonal prism if the height is 6.4 centimeters and the base area is 17.3 square centimeters.

$$\begin{aligned}
 V &= Bh && \text{Volume of a prism} \\
 &= 17.3(6.4) && B = 17.3 \text{ and } h = 6.4 \\
 &= 110.72 && \text{Simplify.}
 \end{aligned}$$

The volume is 110.72 cubic centimeters.

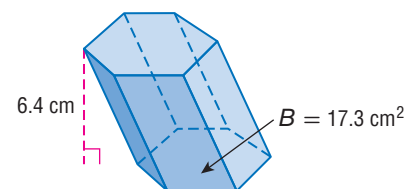

Guided Practice

- Find the volume of an oblique cylinder that has a radius of 5 feet and a height of 3 feet. Round to the nearest tenth.

Standardized Test Example 4 Comparing Volumes of Solids



Prisms A and B have the same length and width, but different heights. If the volume of Prism B is 150 cubic inches greater than the volume of Prism A, what is the length of each prism?

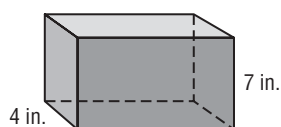

Prism A

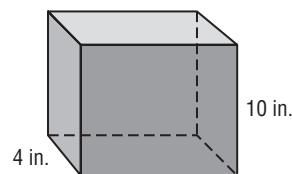

Prism B

- A 10 in. B $11\frac{1}{2}$ in. C 12 in. D $12\frac{1}{2}$ in.

Read the Test Item

You know two dimensions of each solid and that the difference between their volumes is 150 cubic inches.

Solve the Test Item

$$\begin{aligned}
 \text{Volume of Prism B} - \text{Volume of Prism A} &= 150 && \text{Write an equation.} \\
 4\ell \cdot 10 - 4\ell \cdot 7 &= 150 && \text{Use } V = Bh. \\
 12\ell &= 150 && \text{Simplify.} \\
 \ell &= 12\frac{1}{2} && \text{Divide each side by 12.}
 \end{aligned}$$

The length of each prism is $12\frac{1}{2}$ inches. The correct answer is D.

Guided Practice

- The containers at the right are filled with popcorn. About how many times as much popcorn does the larger container hold?

- F 1.6 times as much
G 2.5 times as much
H 3.3 times as much
J 5.0 times as much

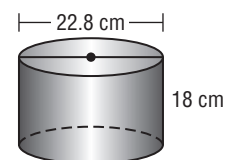
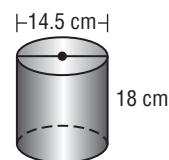

Test-Taking Tip

Writing Equations By choosing a variable to represent the unknown and setting up an equation, you make it easier to check for mistakes as you work out a problem.





Examples 1 and 3 Find the volume of each prism.

1.

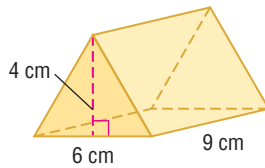

2.

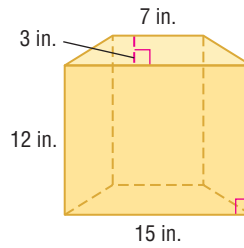

3. the oblique rectangular prism shown at the right

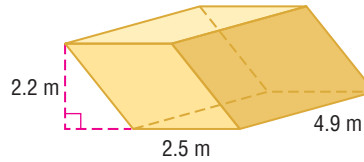

4. an oblique pentagonal prism with a base area of 42 square centimeters and a height of 5.2 centimeters

Examples 2–3 Find the volume of each cylinder. Round to the nearest tenth.

5.

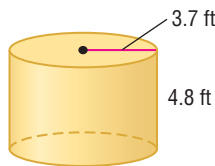

6.

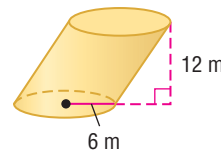

7. a cylinder with a diameter of 16 centimeters and a height of 5.1 centimeters

8. a cylinder with a radius of 4.2 inches and a height of 7.4 inches

Example 4 9. **MULTIPLE CHOICE** A rectangular lap pool measures 80 feet long by 20 feet wide. If it needs to be filled to four feet deep and each cubic foot holds 7.5 gallons, how many gallons will it take to fill the lap pool?

A 4000

B 6400

C 30,000

D 48,000

Practice and Problem Solving

Extra Practice is on page R12.

Examples 1 and 3 **CCSS SENSE-MAKING** Find the volume of each prism.

10.

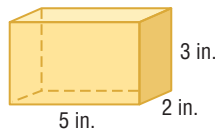

11

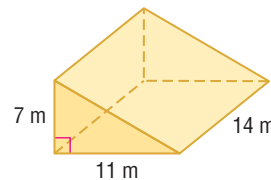

12.

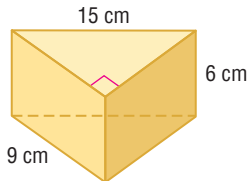

13.

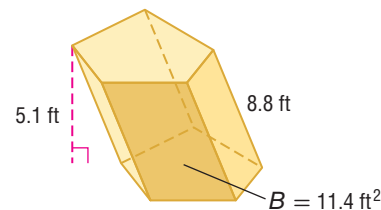

14. an oblique hexagonal prism with a height of 15 centimeters and with a base area of 136 square centimeters

15. a square prism with a base edge of 9.5 inches and a height of 17 inches



Examples 2–3  **SENSE-MAKING** Find the volume of each cylinder. Round to the nearest tenth.

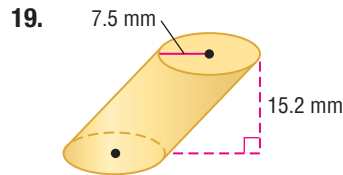
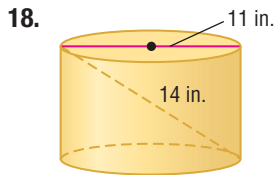
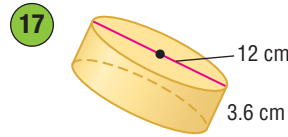
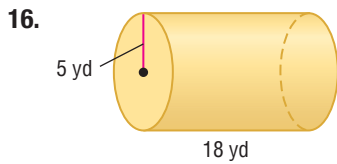

Example 4

20. **PLANTER** A planter is in the shape of a rectangular prism 18 inches long, $14\frac{1}{2}$ inches deep, and 12 inches high. What is the volume of potting soil in the planter if the planter is filled to $1\frac{1}{2}$ inches below the top?

21. **SHIPPING** A box 18 centimeters by 9 centimeters by 15 centimeters is being used to ship two cylindrical candles. Each candle has a diameter of 9 centimeters and a height of 15 centimeters, as shown at the right. What is the volume of the empty space in the box?

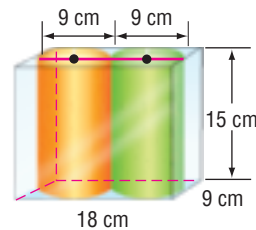

22. **SANDCASTLES** In a sandcastle competition, contestants are allowed to use only water, shovels, and 10 cubic feet of sand. To transport the correct amount of sand, they want to create cylinders that are 2 feet tall to hold enough sand for one contestant. What should the diameter of the cylinders be?

Find the volume of the solid formed by each net.

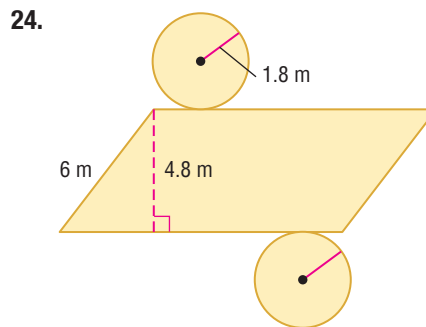
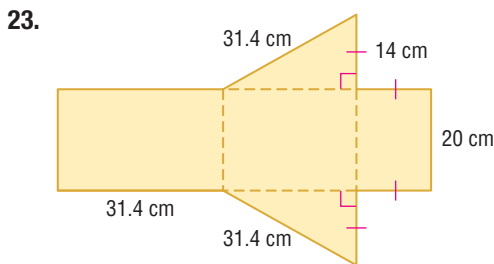

25. **FOOD** A cylindrical can of baked potato chips has a height of 27 centimeters and a radius of 4 centimeters. A new can is advertised as being 30% larger than the regular can. If both cans have the same radius, what is the height of the larger can?

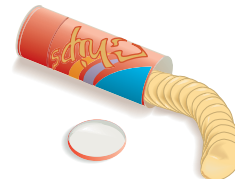

26. **CHANGING DIMENSIONS** A cylinder has a radius of 5 centimeters and a height of 8 centimeters. Describe how each change affects the volume of the cylinder.

- The height is tripled.
- The radius is tripled.
- Both the radius and the height are tripled.
- The dimensions are exchanged.



27. **SOIL** A soil scientist wants to determine the bulk density of a potting soil to assess how well a specific plant will grow in it. The density of the soil sample is the ratio of its weight to its volume.

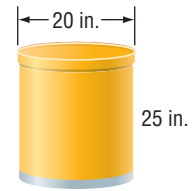

- If the weight of the container with the soil is 20 pounds and the weight of the container alone is 5 pounds, what is the soil's bulk density?
- Assuming that all other factors are favorable, how well should a plant grow in this soil if a bulk density of 0.0018 pound per square inch is desirable for root growth? Explain.
- If a bag of this soil holds 2.5 cubic feet, what is its weight in pounds?

Find the volume of each composite solid. Round to the nearest tenth if necessary.

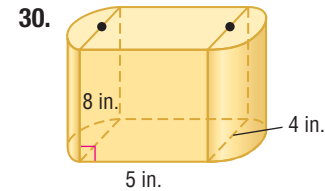
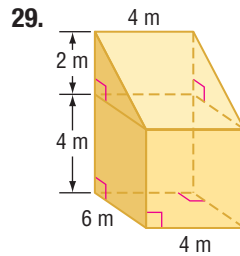
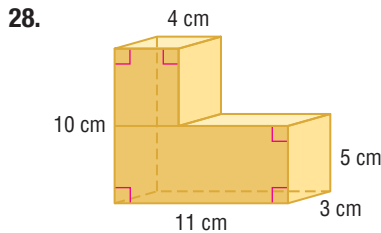

31. **MANUFACTURING** A can 12 centimeters tall fits into a rubberized cylindrical holder that is 11.5 centimeters tall, including 1 centimeter for the thickness of the base of the holder. The thickness of the rim of the holder is 1 centimeter. What is the volume of the rubberized material that makes up the holder?

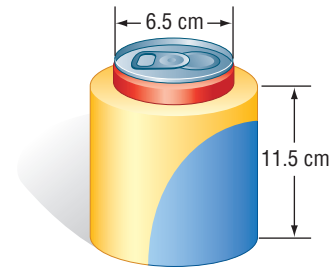

Find each measure to the nearest tenth.

- A cylindrical can has a volume of 363 cubic centimeters. The diameter of the can is 9 centimeters. What is the height?
- A cylinder has a surface area of 144π square inches and a height of 6 inches. What is the volume?
- A rectangular prism has a surface area of 432 square inches, a height of 6 inches, and a width of 12 inches. What is the volume?
- ARCHITECTURE** A cylindrical stainless steel column is used to hide a ventilation system in a new building. According to the specifications, the diameter of the column can be between 30 centimeters and 95 centimeters. The height is to be 500 centimeters. What is the difference in volume between the largest and smallest possible column? Round to the nearest tenth cubic centimeter.

36. **CCSS MODELING** The base of a rectangular swimming pool is sloped so one end of the pool is 6 feet deep and the other end is 3 feet deep, as shown in the figure. If the width is 15 feet, find the volume of water it takes to fill the pool.

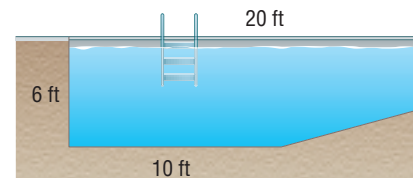

37. **CHANGING DIMENSIONS** A soy milk company is planning a promotion in which the volume of soy milk in each container will be increased by 25%. The company wants the base of the container to stay the same. What will be the height of the new containers?



38. **DESIGN** Sketch and label (in inches) three different designs for a dry ingredient measuring cup that holds 1 cup. Be sure to include the dimensions in each drawing. (1 cup ≈ 14.4375 in³)



- 39 Find the volume of the regular pentagonal prism at the right by dividing it into five equal triangular prisms. Describe the base area and height of each triangular prism.

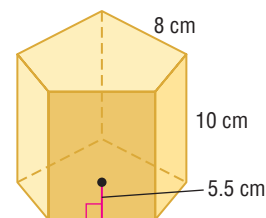

40. **PATIOS** Mr. Thomas is planning to remove an old patio and install a new rectangular concrete patio 20 feet long, 12 feet wide, and 4 inches thick. One contractor bid \$2225 for the project. A second contractor bid \$500 per cubic yard for the new patio and \$700 for removal of the old patio. Which is the less expensive option? Explain.
41. **MULTIPLE REPRESENTATIONS** In this problem, you will investigate cylinders.
- Geometric** Draw a right cylinder and an oblique cylinder with a height of 10 meters and a diameter of 6 meters.
 - Verbal** A square prism has a height of 10 meters and a base edge of 6 meters. Is its volume greater than, less than, or equal to the volume of the cylinder? Explain.
 - Analytical** Describe which change affects the volume of the cylinder more: multiplying the height by x or multiplying the radius by x . Explain.

H.O.T. Problems Use Higher-Order Thinking Skills

42. **CCSS CRITIQUE** Francisco and Valerie each calculated the volume of an equilateral triangular prism with an apothem of 4 units and height of 5 units. Is either of them correct? Explain your reasoning.

Francisco

$$\begin{aligned} V &= Bh \\ &= \frac{1}{2}aP \cdot h \\ &= \frac{1}{2}(4)(24\sqrt{3}) \cdot 5 \\ &= 240\sqrt{3} \text{ cubic units} \end{aligned}$$

Valerie

$$\begin{aligned} V &= Bh \\ &= \frac{\sqrt{3}}{2}s^2 \cdot h \\ &= \frac{\sqrt{3}}{2}(4\sqrt{3})^2 \cdot 5 \\ &= 120\sqrt{3} \text{ cubic units} \end{aligned}$$

43. **CHALLENGE** The cylindrical can below is used to fill a container with liquid. It takes three full cans to fill the container. Describe possible dimensions of the container if it is each of the following shapes.
- rectangular prism
 - square prism
 - triangular prism with a right triangle as the base

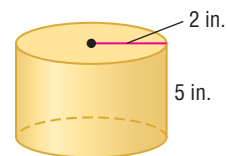

44. **WRITING IN MATH** Write a helpful response to the following question posted on an Internet gardening forum.
- I am new to gardening. The nursery will deliver a truckload of soil, which they say is 4 yards. I know that a yard is 3 feet, but what is a yard of soil? How do I know what to order?*
45. **OPEN ENDED** Draw and label a prism that has a volume of 50 cubic centimeters.
46. **REASONING** Determine whether the following statement is true or false. Explain.
- Two cylinders with the same height and the same lateral area must have the same volume.*
47. **WRITING IN MATH** How are the volume formulas for prisms and cylinders similar? How are they different?



Standardized Test Practice

48. The volume of a triangular prism is 1380 cubic centimeters. Its base is a right triangle with legs measuring 8 centimeters and 15 centimeters. What is the height of the prism?

- A 34.5 cm C 17 cm
B 23 cm D 11.5 cm

49. A cylindrical tank used for oil storage has a height that is half the length of its radius. If the volume of the tank is $1,122,360 \text{ ft}^3$, what is the tank's radius?

- F 89.4 ft H 280.9 ft
G 178.8 ft J 561.8 ft

50. **SHORT RESPONSE** What is the ratio of the area of the circle to the area of the square?

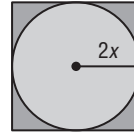

51. **SAT/ACT** A county proposes to enact a new 0.5% property tax. What would be the additional tax amount for a landowner whose property has a taxable value of \$85,000?

- A \$4.25 D \$4250
B \$170 E \$42,500
C \$425

Spiral Review

Find the lateral area and surface area of each regular pyramid. Round to the nearest tenth if necessary. (Lesson 12-3)

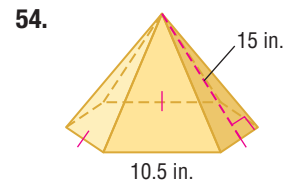
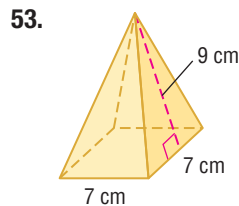
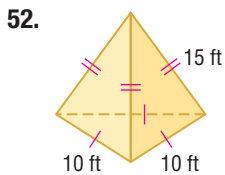

55. **BAKING** Many baking pans are given a special nonstick coating. A rectangular cake pan is 9 inches by 13 inches by 2 inches deep. What is the area of the inside of the pan that needs to be coated? (Lesson 12-2)

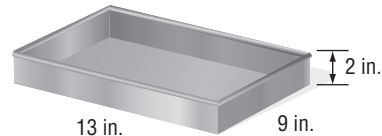

Find the indicated measure. Round to the nearest tenth. (Lesson 11-3)

56. The area of a circle is 54 square meters. Find the diameter.
57. Find the diameter of a circle with an area of 102 square centimeters.
58. The area of a circle is 191 square feet. Find the radius.
59. Find the radius of a circle with an area of 271 square inches.

Skills Review

Find the area of each trapezoid, rhombus, or kite.

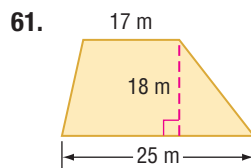
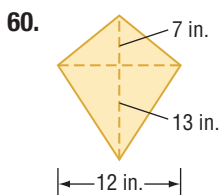

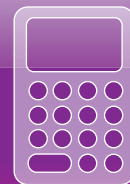

You can use TI-Nspire Technology to investigate how changes in dimension affect the surface area and volume of a rectangular prism.

Activity

Step 1 Open a new **Lists & Spreadsheet** page.

Step 2 Move the cursor to the space beside the letter in each column and label the columns l for length, w for width, h for height, sa for surface area, and v for volume.

Step 3 Insert the values for length, width, and height shown into the table.

Step 4 Enter the formula for the surface area in terms of cells A1, B1, and C1 in cell D1.

Step 5 Enter the formula for the volume in terms of cells A1, B1, and C1 in cell E1.

Step 6 Highlight cell D1 and select **Fill Down** from the **Data** menu. Scroll down to fill in the surface areas for the other prisms. Repeat the process for volume.

Step 7 Add additional values and observe the effect on surface area and volume as one or more of the dimensions changes.

	l	w	h	sa	v
1	1	2	3		
2	1	2	6		
3	1	4	6		
4	2	4	6		
5	3	6	9		

	l	w	h	sa	v
1	1	2	3	22	6
2	1	2	6		
3	1	4	6		
4	2	4	6		
5	3	6	9		

Analyze the Results

- How does the surface area change when one of the dimensions is doubled? two of the dimensions? all three of the dimensions?
- How does the volume change when one of the dimensions is doubled? two of the dimensions? all three of the dimensions?
- How does the surface area change when all three of the dimensions are tripled?
- How does the volume change when all three of the dimensions are tripled?
- MAKE A CONJECTURE** If the dimensions of a prism are all multiplied by a factor of 5, what do you think the ratio of the new surface area to the original surface area will be? the ratio of the new volume to the original volume? Explain.
- CHALLENGE** Write an expression for the ratio of the surface areas and the ratio of the volumes if all three of the dimensions of a prism are increased by a scale factor of k . Explain.

Mid-Chapter Quiz

Lessons 12-1 through 12-4

1. Describe how to use isometric dot paper to sketch the following figure. (Lesson 12-1)

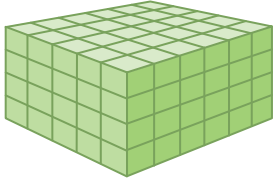

2. Use isometric dot paper to sketch a rectangular prism 2 units high, 3 units long, and 6 units wide. (Lesson 12-1)
3. Use isometric dot paper to sketch a triangular prism 5 units high, with two sides of the base that are 4 units long and 3 units long. (Lesson 12-1)

Find the lateral area of each prism. Round to the nearest tenth if necessary. (Lesson 12-2)

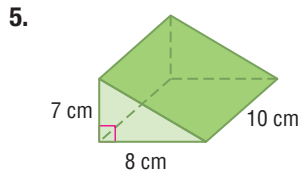
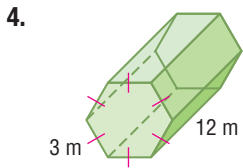

6. **MULTIPLE CHOICE** Coaxial cable is used to transmit long-distance telephone calls, cable television programming, and other communications. A typical coaxial cable contains 22 copper tubes and has a diameter of 3 inches. What is the approximate lateral area of a coaxial cable that is 500 feet long? (Lesson 12-2)

- A 16.4 ft² C 294.5 ft²
 B 196.3 ft² D 392.7 ft²

Find the lateral area and surface area of each cylinder. Round to the nearest tenth if necessary. (Lesson 12-2)

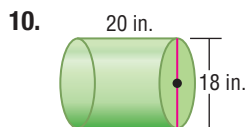
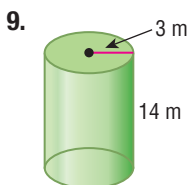
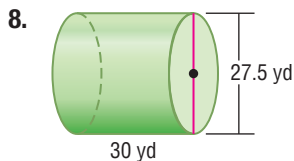
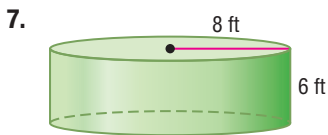

11. **COLLECTIONS** Soledad collects unique salt and pepper shakers. She inherited a pair of tetrahedral shakers from her mother. (Lesson 12-3)
- Each edge of a shaker measures 3 centimeters. Make a sketch of one shaker.
 - Find the total surface area of one shaker.

Find the surface area of each regular pyramid or cone. Round to the nearest tenth if necessary. (Lesson 12-3)

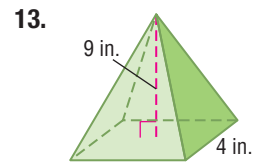
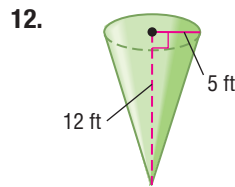

Find the volume of each prism or cylinder. Round to the nearest tenth if necessary. (Lesson 12-4)

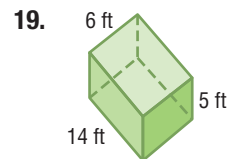
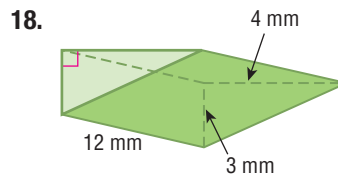
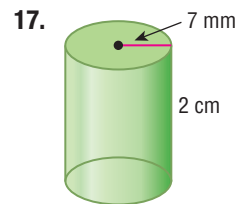
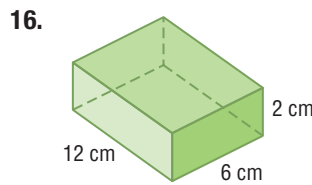
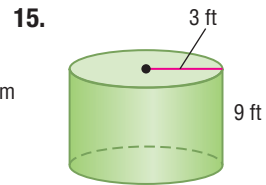
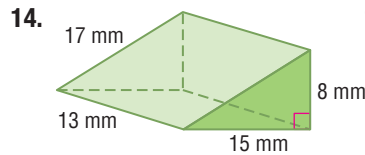

20. **METEOROLOGY** The TIROS weather satellites were a series of weather satellites that carried television and infrared cameras and were covered by solar cells. If the cylinder-shaped body of a TIROS had a diameter of 42 inches and a height of 19 inches, what was the volume available for carrying instruments and cameras? Round to the nearest tenth. (Lesson 12-4)

Then

- You found surface areas of pyramids and cones.

Now

- Find volumes of pyramids.
- Find volumes of cones.

Why?

- Marta is studying crystals that grow on rock formations. For a project, she is making a clay model of a crystal with a shape that is a composite of two congruent rectangular pyramids. The base of each pyramid will be 1 by 1.5 inches, and the total height will be 4 inches. Why is determining the volume of the model helpful in this situation?

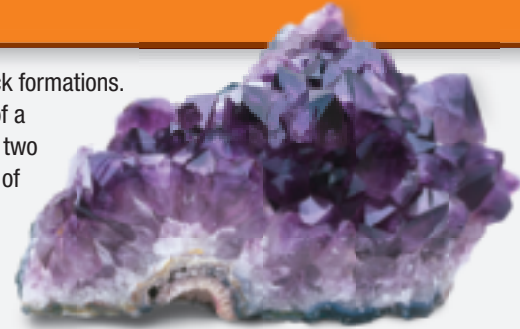

Common Core State Standards

Content Standards

G.GMD.1 Give an informal argument for the formulas for the circumference of a circle, area of a circle, volume of a cylinder, pyramid, and cone.

G.GMD.3 Use volume formulas for cylinders, pyramids, cones, and spheres to solve problems. ★

Mathematical Practices

- Make sense of problems and persevere in solving them.
- Look for and make use of structure.

1 Volume of Pyramids A triangular prism can be separated into three triangular pyramids as shown. Since all faces of a triangular pyramid are triangles, any face can be considered a base of the pyramid.

The yellow and orange pyramids have base area B_1 and height h_1 . Therefore, by Cavalieri's Principle, they have the same volume. Likewise, the yellow and green pyramids have base area B_2 and height h_2 , so they have the same volume.

Since the orange and green pyramids have the same volume as the yellow pyramid, it follows that the volumes of all three pyramids are the same. Therefore, each pyramid has one third the volume of the prism with the same base area and height. This is true for a pyramid with any shape base.

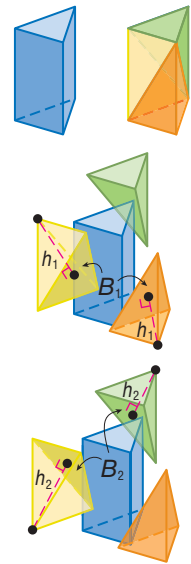

KeyConcept Volume of a Pyramid

Words

The volume of a pyramid is $V = \frac{1}{3}Bh$, where B is the area of the base and h is the height of the pyramid.

Models

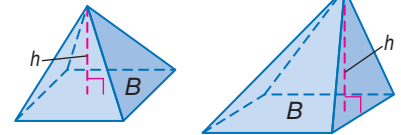

Symbols

$$V = \frac{1}{3}Bh$$

Example 1 Volume of a Pyramid

Find the volume of the pyramid.

$$V = \frac{1}{3}Bh$$

$$= \frac{1}{3}(9.5 \cdot 8)(9)$$

$$= 228$$

Volume of a pyramid

$$B = 9.5 \cdot 8 \text{ and } h = 9$$

Simplify.

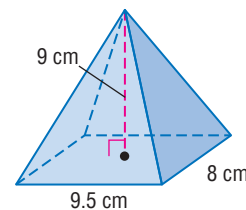

The volume of the pyramid is 228 cubic centimeters.



Guided Practice

1A.

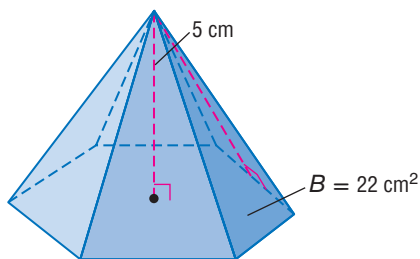

1B.

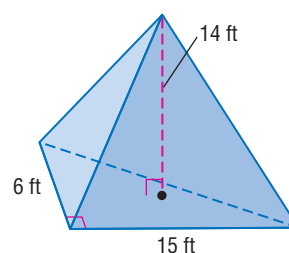

2 Volume of Cones The pyramid and prism shown have the same base area B and height h as the cylinder and cone. Since the volume of the pyramid is one third the volume of the prism, then by Cavalieri's Principle, the volume of the cone must be one third the volume of the cylinder.

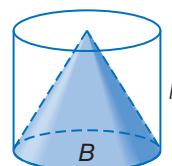
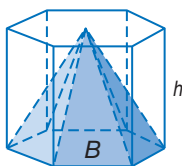

WatchOut!

Volumes of Cones

The formula for the surface area of a cone only applies to right cones. However, the formula for volume applies to oblique cones as well as right cones.

KeyConcept Volume of a Cone

Words

The volume of a circular cone is $V = \frac{1}{3}Bh$, or $V = \frac{1}{3}\pi r^2h$, where B is the area of the base, h is the height of the cone, and r is the radius of the base.

Models

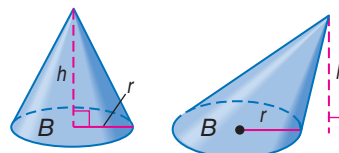

Symbols

$$V = \frac{1}{3}Bh \text{ or } V = \frac{1}{3}\pi r^2h$$

Example 2 Volume of a Cone

a. Find the volume of the cone. Round to the nearest tenth.

$$V = \frac{1}{3}\pi r^2h$$

Volume of a cone

$$\approx \frac{1}{3}\pi(3.2)^2(5.8)$$

$r = 3.2$ and $h = 5.8$

$$\approx 62.2$$

Use a calculator.

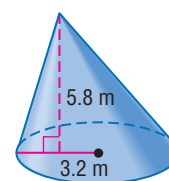

The volume of the cone is approximately 62.2 cubic meters.

b. Find the volume of the cone. Round to the nearest tenth.

Step 1 Use trigonometry to find the radius.

$$\tan 58^\circ = \frac{11}{r}$$

$$\tan \theta = \frac{\text{opp}}{\text{adj}}$$

$$r = \frac{11}{\tan 58^\circ}$$

Solve for r .

$$r \approx 6.9$$

Use a calculator.

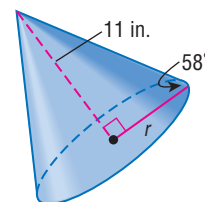

Step 2 Find the volume.

$$V = \frac{1}{3}\pi r^2 h$$

$$\approx \frac{1}{3}\pi(6.9)^2(11)$$

$$\approx 548.4$$

Volume of a cone

$r \approx 6.9$ and $h = 11$

Use a calculator.

The volume of the cone is approximately 548.4 cubic inches.

Guided Practice

2A.

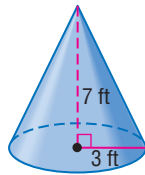

2B.

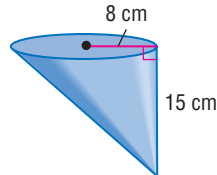

2C.

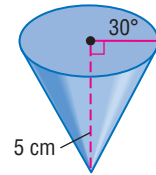

Real-World Link

The Washington Monument is the largest masonry structure in the world. By law, no other building in D.C. is allowed to be taller than the 555-foot-tall structure.

Source: Enchanted Learning

Real-World Example 3 Find Real-World Volumes

ARCHITECTURE At the top of the Washington Monument is a small square pyramid, called a *pyramidion*. This pyramid has a height of 55.5 feet with base edges of approximately 34.5 feet. What is the volume of the pyramidion? Round to the nearest tenth.

Sketch and label the pyramid.

$$V = \frac{1}{3}Bh$$

Volume of a pyramid

$$= \frac{1}{3}(34.5 \cdot 34.5)(55.5)$$

$B = 34.5 \cdot 34.5$, $h = 55.5$

$$\approx 22,019.6$$

Simplify.

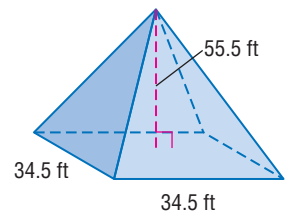

The volume of the pyramidion atop the Washington Monument is about 22,019.6 cubic feet.

Guided Practice

3. **ARCHAEOLOGY** A pyramidion that was discovered in Saqqara, Egypt, in 1992 has a rectangular base 53 centimeters by 37 centimeters. It is 46 centimeters high. What is the volume of this pyramidion? Round to the nearest tenth.

The formulas for the volumes of solids are summarized below.

Concept Summary Volumes of Solids

Solid	prism	cylinder	pyramid	cone
Model				
Volume	$V = Bh$	$V = Bh$ or $V = \pi r^2 h$	$V = \frac{1}{3}Bh$	$V = \frac{1}{3}Bh$ or $V = \frac{1}{3}\pi r^2 h$



Example 1 Find the volume of each pyramid.

1.

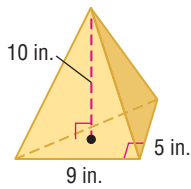

2.

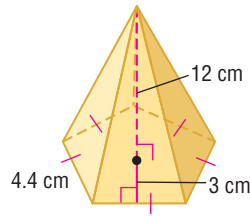

3. a rectangular pyramid with a height of 5.2 meters and a base 8 meters by 4.5 meters

4. a square pyramid with a height of 14 meters and a base with 8-meter side lengths

Example 2 Find the volume of each cone. Round to the nearest tenth.

5.

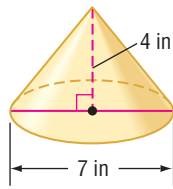

6.

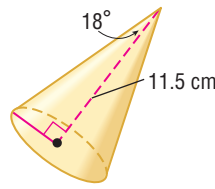

7. an oblique cone with a height of 10.5 millimeters and a radius of 1.6 millimeters

8. a cone with a slant height of 25 meters and a radius of 15 meters

Example 3

9. **MUSEUMS** The sky dome of the National Corvette Museum in Bowling Green, Kentucky, is a conical building. If the height is 100 feet and the area of the base is about 15,400 square feet, find the volume of air that the heating and cooling systems would have to accommodate. Round to the nearest tenth.

Practice and Problem Solving

Extra Practice is on page R12.

Example 1

CCSS SENSE-MAKING Find the volume of each pyramid. Round to the nearest tenth if necessary.

10.

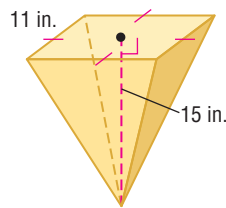

11

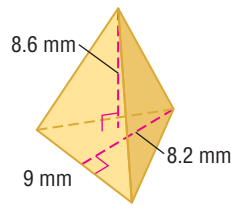

12.

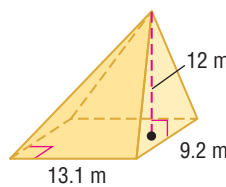

13.

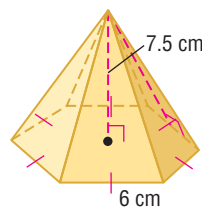

14. a pentagonal pyramid with a base area of 590 square feet and an altitude of 7 feet

15. a triangular pyramid with a height of 4.8 centimeters and a right triangle base with a leg 5 centimeters and hypotenuse 10.2 centimeters

16. A triangular pyramid with a right triangle base with a leg 8 centimeters and hypotenuse 10 centimeters has a volume of 144 cubic centimeters. Find the height.



Example 2 Find the volume of each cone. Round to the nearest tenth.

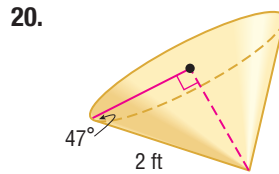
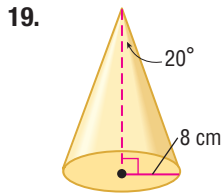
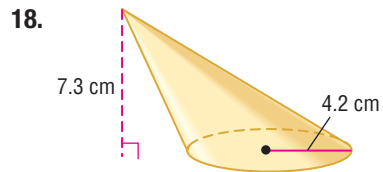
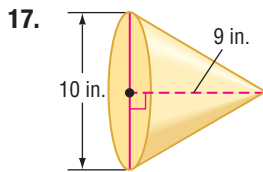

21. an oblique cone with a diameter of 16 inches and an altitude of 16 inches
22. a right cone with a slant height of 5.6 centimeters and a radius of 1 centimeter

Example 3

23. **SNACKS** Approximately how many cubic centimeters of roasted peanuts will completely fill a paper cone that is 14 centimeters high and has a base diameter of 8 centimeters? Round to the nearest tenth.
24. **CCSS MODELING** The Pyramid Arena in Memphis, Tennessee, is the third largest pyramid in the world. It is approximately 350 feet tall, and its square base is 600 feet wide. Find the volume of this pyramid.

25. **GARDENING** The greenhouse at the right is a regular octagonal pyramid with a height of 5 feet. The base has side lengths of 2 feet. What is the volume of the greenhouse?



Find the volume of each solid. Round to the nearest tenth.

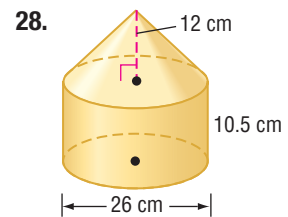
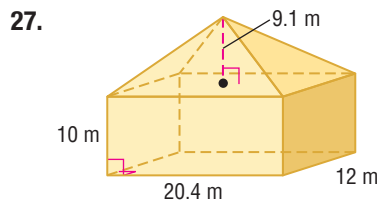
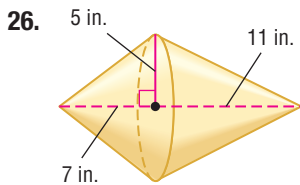

29. **HEATING** Sam is building an art studio in her backyard. To buy a heating unit for the space, she needs to determine the BTUs (British Thermal Units) required to heat the building. For new construction with good insulation, there should be 2 BTUs per cubic foot. What size unit does Sam need to purchase?

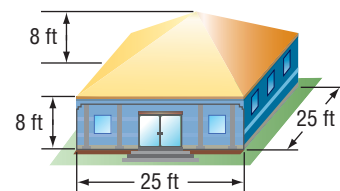

30. **SCIENCE** Refer to page 873. Determine the volume of the model. Explain why knowing the volume is helpful in this situation.

31. **CHANGING DIMENSIONS** A cone has a radius of 4 centimeters and a height of 9 centimeters. Describe how each change affects the volume of the cone.
- The height is doubled.
 - The radius is doubled.
 - Both the radius and the height are doubled.

Find each measure. Round to the nearest tenth if necessary.

32. A square pyramid has a volume of 862.5 cubic centimeters and a height of 11.5 centimeters. Find the side length of the base.
33. The volume of a cone is 196π cubic inches and the height is 12 inches. What is the diameter?
34. The lateral area of a cone is 71.6 square millimeters and the slant height is 6 millimeters. What is the volume of the cone?
35. **MULTIPLE REPRESENTATIONS** In this problem, you will investigate rectangular pyramids.
- Geometric** Draw two pyramids with different bases that have a height of 10 centimeters and a base area of 24 square centimeters.
 - Verbal** What is true about the volumes of the two pyramids that you drew? Explain.
 - Analytical** Explain how multiplying the base area and/or the height of the pyramid by 5 affects the volume of the pyramid.

H.O.T. Problems Use Higher-Order Thinking Skills

36. **CCSS ARGUMENTS** Determine whether the following statement is *always*, *sometimes*, or *never* true. Justify your reasoning.

The volume of a cone with radius r and height h equals the volume of a prism with height h .

37. **ERROR ANALYSIS** Alexandra and Cornelio are calculating the volume of the cone at the right. Is either of them correct? Explain your answer.

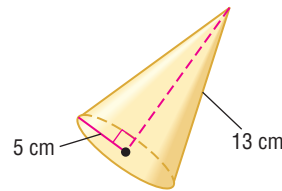

Alexandra

$$\begin{aligned} V &= \frac{1}{3}Bh \\ &= \frac{1}{3}\pi(5^2)(13) \\ &\approx 340.3 \text{ cm}^3 \end{aligned}$$

Cornelio

$$\begin{aligned} 5^2 + 12^2 &= 13^2 \\ V &= \frac{1}{3}Bh \\ &= \frac{1}{3}\pi(5^2)(12) \\ &\approx 314.2 \text{ cm}^3 \end{aligned}$$

38. **REASONING** A cone has a volume of 568 cubic centimeters. What is the volume of a cylinder that has the same radius and height as the cone? Explain your reasoning.
39. **OPEN ENDED** Give an example of a pyramid and a prism that have the same base and the same volume. Explain your reasoning.
40. **WRITING IN MATH** Compare and contrast finding volumes of pyramids and cones with finding volumes of prisms and cylinders.



Standardized Test Practice

41. A conical sand toy has the dimensions as shown below. How many cubic centimeters of sand will it hold when it is filled to the top?

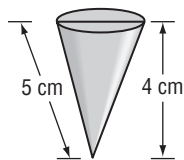

- A 12π C $\frac{80}{3}\pi$
 B 15π D $\frac{100}{3}\pi$

42. **SHORT RESPONSE** Brooke is buying a tent that is in the shape of a rectangular pyramid. The base is 6 feet by 8 feet. If the tent holds 88 cubic feet of air, how tall is the tent's center pole?

43. **PROBABILITY** A spinner has sections colored red, blue, orange, and green. The table below shows the results of several spins. What is the experimental probability of the spinner landing on orange?

Color	Frequency
red	6
blue	4
orange	5
green	10

- F $\frac{1}{5}$ H $\frac{9}{25}$
 G $\frac{1}{4}$ J $\frac{1}{2}$

44. **SAT/ACT** For all $x \neq -2$ or 0 , $\frac{x^2 - 2x - 8}{x^2 + 2x} = ?$

- A -8 D $\frac{-8}{x+2}$
 B $x - 4$ E $\frac{x-4}{x}$
 C $\frac{-x-4}{x}$

Spiral Review

Find the volume of each prism. (Lesson 12-4)

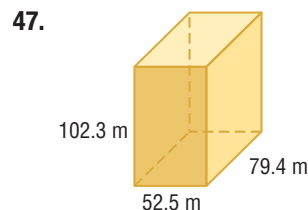
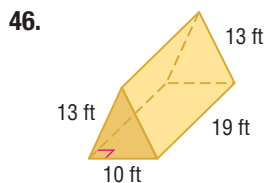
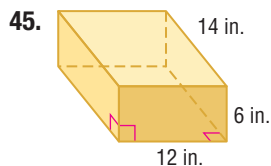

48. **FARMING** The picture shows a combination hopper cone and bin used by farmers to store grain after harvest. The cone at the bottom of the bin allows the grain to be emptied more easily. Use the dimensions in the diagram to find the entire surface area of the bin with a conical top and bottom. Write the exact answer and the answer rounded to the nearest square foot. (Lesson 12-3)

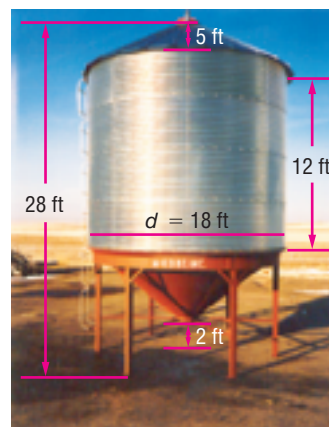

Skills Review

Find the area of each shaded region. The polygons in Exercises 50-52 are regular.

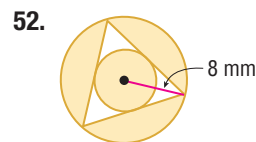
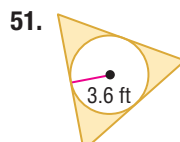
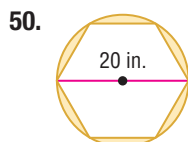
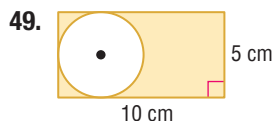

LESSON 12-6 Surface Areas and Volumes of Spheres

Then

- You found surface areas of prisms and cylinders.

Now

- Find surface areas of spheres.
- Find volumes of spheres.

Why?

- When you blow bubbles, soapy liquid surrounds a volume of air. Because of surface tension, the liquid maintains a shape that minimizes the surface area surrounding the air. The shape that minimizes surface area per unit of volume is a sphere.



New Vocabulary

great circle
pole
hemisphere



Common Core State Standards

Content Standards

G.GMD.1 Give an informal argument for the formulas for the circumference of a circle, area of a circle, volume of a cylinder, pyramid, and cone.

G.GMD.3 Use volume formulas for cylinders, pyramids, cones, and spheres to solve problems. ★

Mathematical Practices

- Make sense of problems and persevere in solving them.
- Attend to precision.

1 Surface Area of Spheres Recall that a *sphere* is the locus of all points in space that are a given distance from a given point called the *center* of the sphere.

- A *radius* of a sphere is a segment from the center to a point on the sphere.
- A *chord* of a sphere is a segment that connects any two points on the sphere.
- A *diameter* of a sphere is a chord that contains the center.
- A *tangent* to a sphere is a line that intersects the sphere in exactly one point.

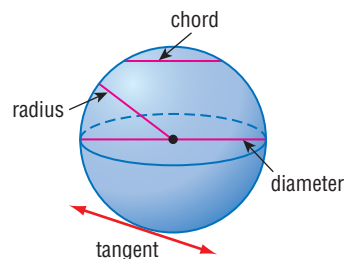

To develop a formula for the surface area of a sphere, consider a tennis ball. The covering of this sphere is comprised of two congruent dumbbell-shaped pieces, each of which can be approximated by two congruent circles with radii equal to that of the sphere. So, the entire covering consists of approximately four congruent circles. The sum of these areas approximates the surface area of the sphere.

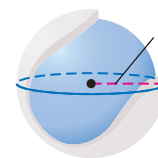

$$S \approx 4A \quad \text{Sum of circles with area } A$$

$$\approx 4(\pi r^2) \text{ or } 4\pi r^2 \quad A = \pi r^2$$

While its derivation is beyond the scope of this course, the exact formula is in fact $S = 4\pi r^2$.

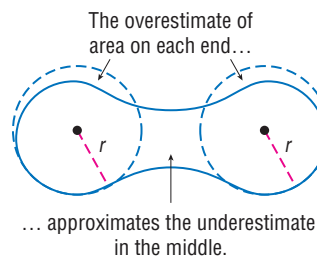

Key Concept Surface Area of a Sphere

Words The surface area S of a sphere is $S = 4\pi r^2$, where r is the radius.

Symbols $S = 4\pi r^2$

Model

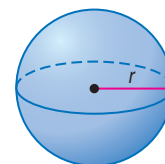

Example 1 Surface Area of a Sphere

Find the surface area of the sphere. Round to the nearest tenth.

$$\begin{aligned}
 S &= 4\pi r^2 && \text{Surface area of a sphere} \\
 &= 4\pi(6)^2 && \text{Replace } r \text{ with } 6. \\
 &\approx 452.4 && \text{Use a calculator.}
 \end{aligned}$$

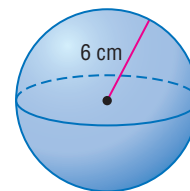

The surface area is about 452.4 square centimeters.

Guided Practice

1A.

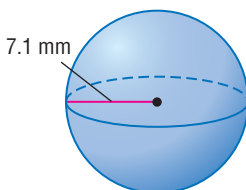

1B.

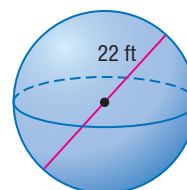

StudyTip

Great Circles A sphere has an infinite number of great circles.

A plane can intersect a sphere in a point or in a circle. If the circle contains the center of the sphere, the intersection is called a **great circle**. The endpoints of a diameter of a great circle are called **poles**.

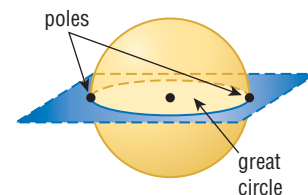
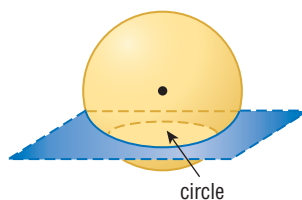
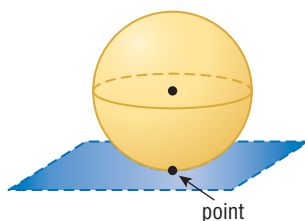

Since a great circle has the same center as the sphere and its radii are also radii of the sphere, it is the largest circle that can be drawn on a sphere. A great circle separates a sphere into two congruent halves, called **hemispheres**.

WatchOut!

Area of Hemisphere
When finding the surface area of a hemisphere, do not forget to include the area of the great circle.

Example 2 Use Great Circles to Find Surface Area

a. Find the surface area of the hemisphere.

Find half the area of a sphere with a radius of 2.8 centimeters. Then add the area of the great circle.

$$\begin{aligned}
 S &= \frac{1}{2}(4\pi r^2) + \pi r^2 && \text{Surface area of a hemisphere} \\
 &= \frac{1}{2}[4\pi(2.8)^2] + \pi(2.8)^2 && \text{Replace } r \text{ with } 2.8. \\
 &\approx 73.9 \text{ cm}^2 && \text{Use a calculator.}
 \end{aligned}$$

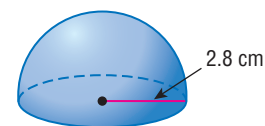

b. Find the surface area of a sphere if the circumference of the great circle is 5π meters.

First, find the radius. The circumference of a great circle is $2\pi r$. So, $2\pi r = 5\pi$ or $r = 2.5$.

$$\begin{aligned}
 S &= 4\pi r^2 && \text{Surface area of a sphere} \\
 &= 4\pi(2.5)^2 && \text{Replace } r \text{ with } 2.5. \\
 &\approx 78.5 \text{ m}^2 && \text{Use a calculator.}
 \end{aligned}$$

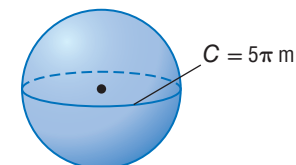

- c. Find the surface area of a sphere if the area of the great circle is approximately 130 square inches.

First, find the radius. The area of a great circle is πr^2 . So, $\pi r^2 = 130$ or $r \approx 6.4$.

$$S = 4\pi r^2$$

Surface area of a sphere

$$\approx 4\pi(6.4)^2 \text{ or about } 514.7 \text{ in}^2$$

Replace r with 6.4. Use a calculator.

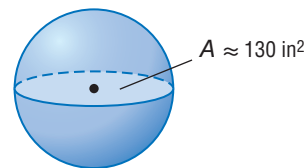

Guided Practice

Find the surface area of each figure. Round to the nearest tenth if necessary.

- 2A. sphere: circumference of great circle = 16.2π ft
 2B. hemisphere: area of great circle $\approx 94 \text{ mm}^2$
 2C. hemisphere: circumference of great circle = 36π cm

2 Volume of Spheres Suppose a sphere with radius r contains infinitely many pyramids with vertices at the center of the sphere. Each pyramid has height r and base area B . The sum of the volumes of all the pyramids equals the volume of the sphere.

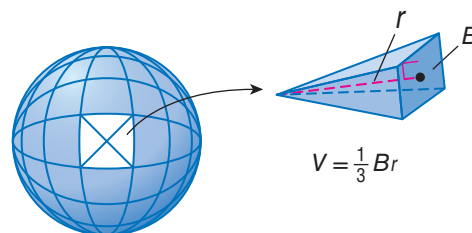

$$V = \frac{1}{3}B_1r_1 + \frac{1}{3}B_2r_2 + \dots + \frac{1}{3}B_n r_n$$

Sum of volumes of pyramids

$$= \frac{1}{3}r(B_1 + B_2 + \dots + B_n)$$

Distributive Property

$$= \frac{1}{3}r(4\pi r^2)$$

The sum of the pyramid base areas equals the surface area of the sphere.

$$= \frac{4}{3}\pi r^3$$

Simplify.

StudyTip

Draw a Diagram When solving problems involving volumes of solids, it is helpful to draw and label a diagram when no diagram is provided.

KeyConcept Volume of a Sphere

Words The volume V of a sphere is $V = \frac{4}{3}\pi r^3$, where r is the radius of the sphere.

Model

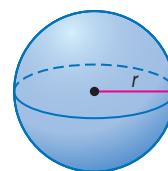

Symbols $V = \frac{4}{3}\pi r^3$



Example 3 Volumes of Spheres and Hemispheres

Find the volume of each sphere or hemisphere. Round to the nearest tenth.

- a. a hemisphere with a radius of 6 meters

$$\text{Estimate: } V \approx \frac{1}{2} \cdot \frac{4}{3} \cdot \frac{4^2}{3^1} \cdot 6^3 \text{ or } 432 \text{ m}^3$$

$$V = \frac{1}{2} \left(\frac{4}{3}\pi r^3 \right)$$

Volume of a hemisphere

$$= \frac{2}{3}\pi(6)^3 \text{ or about } 452.4 \text{ m}^3$$

Replace r with 6. Use a calculator.

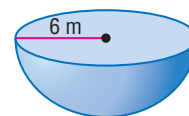

The volume of the hemisphere is about 452.4 cubic meters. This is close to the estimate, so the answer is reasonable.

StudyTip

CCSS Precision Remember to use the correct units when giving your answers. As with other solids, the surface area of a sphere is measured in square units, and volume is measured in cubic units.

b. a sphere with a great circle circumference of 18π centimeters

Step 1 Find the radius of the sphere.

$$\begin{aligned} C &= 2\pi r && \text{Circumference of a circle} \\ 18\pi &= 2\pi r && \text{Replace } C \text{ with } 18\pi. \\ r &= 9 && \text{Solve for } r. \end{aligned}$$

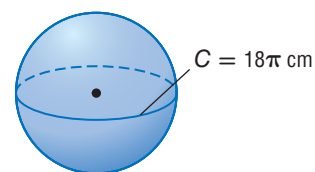

Step 2 Find the volume.

$$\begin{aligned} V &= \frac{4}{3}\pi r^3 && \text{Volume of a sphere} \\ &= \frac{4}{3}\pi(9)^3 \text{ or about } 3053.6 \text{ cm}^3 && \text{Replace } r \text{ with } 9. \text{ Use a calculator.} \end{aligned}$$

GuidedPractice

3A. sphere: diameter = 7.4 in.

3B. hemisphere: area of great circle $\approx 249 \text{ mm}^2$



Real-WorldLink

The University of North Carolina has won the greatest number of national championships in women's soccer since the first tournament in 1982. As of 2009, they have won 18 times.

Source: Fact Monster

Raleigh News & Observer/Contributor/McClatchy-Tribune/Getty Images

Real-World Example 4 Solve Problems Involving Solids

SOCCER The soccer ball globe at the right was constructed for the 2006 World Cup soccer tournament. It takes up $47,916\pi$ cubic feet of space. Assume that the globe is a sphere. What is the circumference of the globe?



Understand You know that the volume of the globe is $47,916\pi$ cubic feet. The circumference of the globe is the circumference of the great circle.

Plan First use the volume formula to find the radius. Then find the circumference of the great circle.

$$\begin{aligned} \text{Solve} \quad V &= \frac{4}{3}\pi r^3 && \text{Volume of a sphere} \\ 47,916\pi &= \frac{4}{3}\pi r^3 && \text{Replace } V \text{ with } 47,916\pi. \\ 35,937 &= r^3 && \text{Divide each side by } \frac{4}{3}\pi. \end{aligned}$$

Use a calculator to find $\sqrt[3]{35,937}$.

$$35937 \left[\wedge \right] \left[(\right] 1 \left[\div \right] 3 \left[) \right] \left[\text{ENTER} \right] 33$$

The radius of the globe is 33 feet. So, the circumference is $2\pi r = 2\pi(33)$ or approximately 207.3 feet.

Check You can work backward to check the solution.

If $C \approx 207.3$, then $r \approx 33$. If $r \approx 33$, then $V \approx \frac{4}{3}\pi \cdot 33^3$ or about $47,917\pi$ cubic feet. The solution is correct. ✓

GuidedPractice

4. **BALLOONS** Ren inflates a spherical balloon to a circumference of about 14 inches. He then adds more air to the balloon until the circumference is about 18 inches. What volume of air was added to the balloon?





Examples 1–2 Find the surface area of each sphere or hemisphere. Round to the nearest tenth.

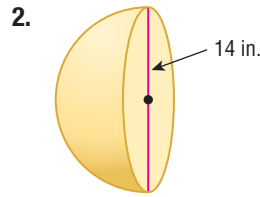
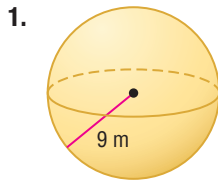

- 3. sphere: area of great circle = 36π yd²
- 4. hemisphere: circumference of great circle ≈ 26 cm

Example 3 Find the volume of each sphere or hemisphere. Round to the nearest tenth.

- 5. sphere: radius = 10 ft
- 6. hemisphere: diameter = 16 cm
- 7. hemisphere: circumference of great circle = 24π m
- 8. sphere: area of great circle = 55π in²

Example 4 9. **BASKETBALL** Basketballs used in professional games must have a circumference of $29\frac{1}{2}$ inches. What is the surface area of a basketball used in a professional game?

Practice and Problem Solving

Extra Practice is on page R12.

Examples 1–2 Find the surface area of each sphere or hemisphere. Round to the nearest tenth.

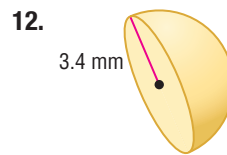
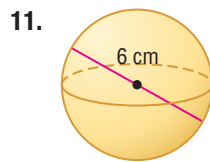
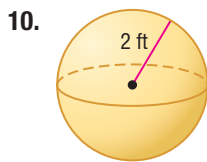

- 14. sphere: circumference of great circle = 2π cm
- 15. sphere: area of great circle ≈ 32 ft²
- 16. hemisphere: area of great circle ≈ 40 in²
- 17. hemisphere: circumference of great circle = 15π mm

Example 3  **PRECISION** Find the volume of each sphere or hemisphere. Round to the nearest tenth.

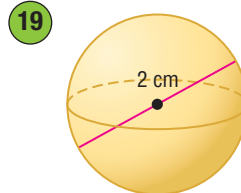
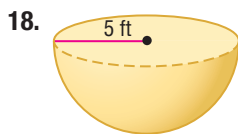

- 20. sphere: radius = 1.4 yd
- 21. hemisphere: diameter = 21.8 cm
- 22. sphere: area of great circle = 49π m²
- 23. sphere: circumference of great circle ≈ 22 in.
- 24. hemisphere: circumference of great circle ≈ 18 ft
- 25. hemisphere: area of great circle ≈ 35 m²



Example 4

26. **FISH** A puffer fish is able to “puff up” when threatened by gulping water and inflating its body. The puffer fish at the right is approximately a sphere with a diameter of 5 inches. Its surface area when inflated is about 1.5 times its normal surface area. What is the surface area of the fish when it is *not* puffed up?



27. **ARCHITECTURE** The Reunion Tower in Dallas, Texas, is topped by a spherical dome that has a surface area of approximately $13,924\pi$ square feet. What is the volume of the dome? Round to the nearest tenth.



28. **TREE HOUSE** The spherical tree house, or *tree sphere*, shown at the right has a diameter of 10.5 feet. Its volume is 1.8 times the volume of the first tree sphere that was built. What was the diameter of the first tree sphere? Round to the nearest foot.

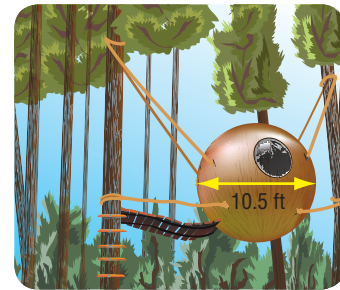

CCSS SENSE-MAKING Find the surface area and the volume of each solid. Round to the nearest tenth.

29.

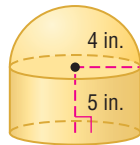

30.

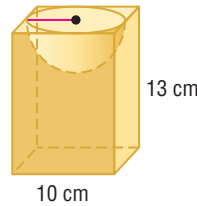

31. **TOYS** The spinning top at the right is a composite of a cone and a hemisphere.
- Find the surface area and the volume of the top. Round to the nearest tenth.
 - If the manufacturer of the top makes another model with dimensions that are one-half of the dimensions of this top, what are its surface area and volume?

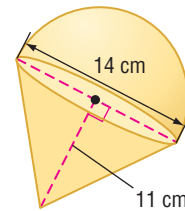

32. **BALLOONS** A spherical helium-filled balloon with a diameter of 30 centimeters can lift a 14-gram object. Find the size of a balloon that could lift a person who weighs 65 kilograms. Round to the nearest tenth.

Use sphere S to name each of the following.

- a chord
- a radius
- a diameter
- a tangent
- a great circle

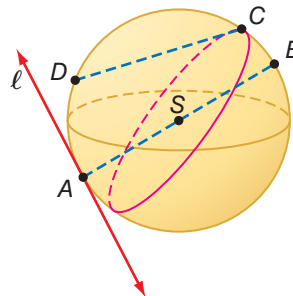

38. **DIMENSIONAL ANALYSIS** Which has greater volume: a sphere with a radius of 2.3 yards or a cylinder with a radius of 4 feet and height of 8 feet?



39. **INFORMAL PROOF** A sphere with radius r can be thought of as being made up of a large number of discs or thin cylinders. Consider the disc shown that is x units above or below the center of the sphere. Also consider a cylinder with radius r and height $2r$ that is hollowed out by two cones of height and radius r .

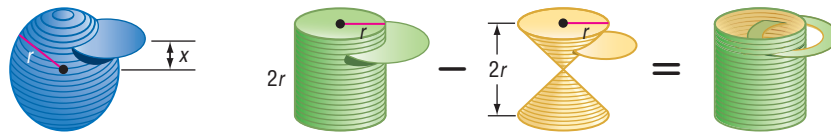

- Find the radius of the disc from the sphere in terms of its distance x above the sphere's center. (*Hint: Use the Pythagorean Theorem.*)
- If the disc from the sphere has a thickness of y units, find its volume in terms of x and y .
- Show that this volume is the same as that of the hollowed-out disc with thickness of y units that is x units above the center of the cylinder and cone.
- Since the expressions for the discs at the same height are the same, what guarantees that the hollowed-out cylinder and sphere have the same volume?
- Use the formulas for the volumes of a cylinder and a cone to derive the formula for the volume of the hollowed-out cylinder and thus, the sphere.

CCSS TOOLS Describe the number and types of planes that produce reflection symmetry in each solid. Then describe the angles of rotation that produce rotation symmetry in each solid.

40. sphere

41. hemisphere

CHANGING DIMENSIONS A sphere has a radius of 12 centimeters. Describe how each change affects the surface area and the volume of the sphere.

42. The radius is multiplied by 4.

43. The radius is divided by 3.

44. **DESIGN** A standard juice box holds 8 fluid ounces.

- Sketch designs for three different juice containers that will each hold 8 fluid ounces. Label dimensions in centimeters. At least one container should be cylindrical. (*Hint: 1 fl oz \approx 29.57353 cm³*)
- For each container in part **a**, calculate the surface area to volume (cm² per fl oz) ratio. Use these ratios to decide which of your containers can be made for the lowest materials cost. What shape container would minimize this ratio, and would this container be the cheapest to produce? Explain your reasoning.

H.O.T. Problems Use Higher-Order Thinking Skills

- CHALLENGE** A cube has a volume of 216 cubic inches. Find the volume of a sphere that is circumscribed about the cube. Round to the nearest tenth.
- REASONING** Determine whether the following statement is *true* or *false*. If true, explain your reasoning. If false, provide a counterexample.

If a sphere has radius r , there exists a cone with radius r having the same volume.

- OPEN ENDED** Sketch a sphere showing two examples of great circles. Sketch another sphere showing two examples of circles formed by planes intersecting the sphere that are *not* great circles.
- WRITING IN MATH** Write a ratio comparing the volume of a sphere with radius r to the volume of a cylinder with radius r and height $2r$. Then describe what the ratio means.



Standardized Test Practice

- 49. GRIDDED RESPONSE** What is the volume of the hemisphere shown below in cubic meters?

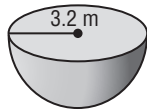

- 50. ALGEBRA** What is the solution set of $3z + 4 < 6 + 7z$?

- A $\{z | z > -0.5\}$ C $\{z | z < -0.5\}$
 B $\{z | z > -2\}$ D $\{z | z < -2\}$

- 51.** If the area of the great circle of a sphere is 33 ft^2 , what is the surface area of the sphere?

- F 42 ft^2 H 132 ft^2
 G 117 ft^2 J 264 ft^2

- 52. SAT/ACT** If a line ℓ is a perpendicular bisector of segment AB at E , how many points on line ℓ are the same distance from point A as from point B ?

- A none D three
 B one E all points
 C two

Spiral Review

Find the volume of each pyramid. Round to the nearest tenth if necessary. (Lesson 12-5)

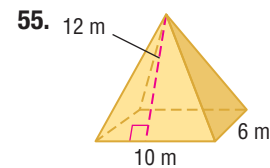
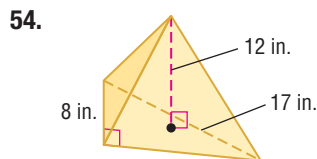
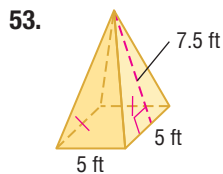

- 56. ENGINEERING** The base of an oil drilling platform is made up of 24 concrete cylindrical cells. Twenty of the cells are used for oil storage. The pillars that support the platform deck rest on the four other cells. Find the total volume of the storage cells. (Lesson 12-4)

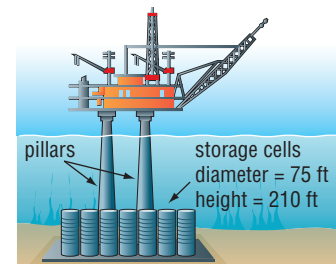

Find the area of each shaded region. Round to the nearest tenth. (Lesson 11-4)

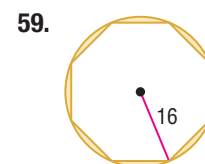
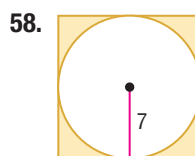
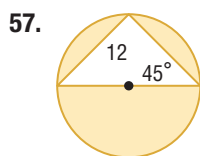

COORDINATE GEOMETRY Find the area of each figure. (Lesson 11-1)

- 60.** $\square WXYZ$ with $W(0, 0)$, $X(4, 0)$, $Y(5, 5)$, and $Z(1, 5)$
61. $\triangle ABC$ with $A(2, -3)$, $B(-5, -3)$, and $C(-1, 3)$

Skills Review

Refer to the figure.

- 62.** How many planes appear in this figure?
63. Name three points that are collinear.
64. Are points G , A , B , and E coplanar? Explain.
65. At what point do \overleftrightarrow{EF} and \overleftrightarrow{AB} intersect?

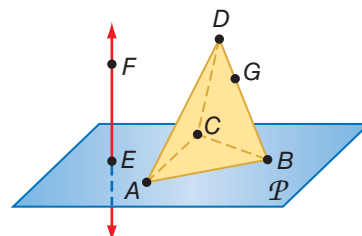



Spheres are defined in terms of a locus of points in space. The definition of a sphere is the set of all points that are a given distance from a given point.



Activity 1 Locus of Points a Given Distance from Endpoints

Find the locus of all points that are equidistant from a segment.

Collect the Data

- Draw a given line segment with endpoints J and K
- Create a set of points that are equidistant from the segment.

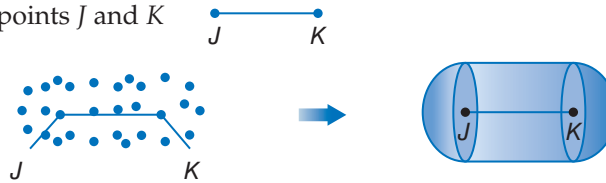

Analyze

1. Draw a figure and describe the locus of points in space that are 8 units from a segment that is 30 units long.
2. What three-dimensional shapes form the figure?
3. What are the radii and diameters of each hemisphere?
4. What are the diameter and the height of the cylinder?

Activity 2 Spheres That Intersect

Find the locus of all points that are equidistant from the centers of two intersecting spheres with the same radius.

Collect the Data

- Draw a line segment.
- Draw congruent overlapping spheres, with the centers at the endpoints of the given line segment.

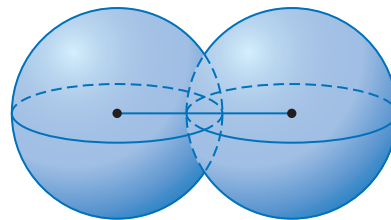

Analyze

5. What is the shape of the intersection of the upper hemispheres?
6. Can this be described as a locus of points in space or on a plane? Explain.
7. Describe this intersection as a locus.
8. **FIREWORKS** What is the locus of points that describes how particles from a fireworks explosion will disperse in an explosion at 400 feet above ground level if the expected distance a particle could travel is 200 feet?

Spherical Geometry



Then

- You identified basic properties of spheres.

Now

- Describe sets of points on a sphere.
- Compare and contrast Euclidean and spherical geometries.

Why?

- Since Earth has a curved instead of a flat surface, the shortest path between two points on Earth is described by an arc of a great circle instead of a straight line.



New Vocabulary

- Euclidean geometry
- spherical geometry
- non-Euclidean geometry

1 Geometry on a Sphere In this text, we have studied **Euclidean geometry**, either in the plane or in space. In plane Euclidean geometry, a *plane* is a flat surface made up of points that extend infinitely in all directions. In **spherical geometry**, or geometry on a sphere, a plane is the surface of a sphere.

Lines are also defined differently in spherical geometry.

KeyConcept Lines in Plane and Spherical Geometry

Plane Euclidean Geometry

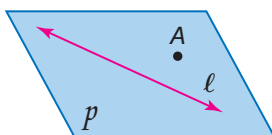

Plane \mathcal{P} contains line ℓ and point A not on line ℓ .

Spherical Geometry

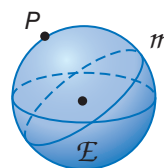

Sphere \mathcal{E} contains great circle m and point P not on m . Great circle m is a line on sphere \mathcal{E} .

Example 1 Describe Sets of Points on a Sphere

Name each of the following on sphere \mathcal{F} .

- two lines containing point R
 \overleftrightarrow{GP} and \overleftrightarrow{MQ} are lines on sphere \mathcal{F} that contain point R .
- a segment containing point K
 \overline{PS} is a segment on sphere \mathcal{F} that contains point K .
- a triangle
 $\triangle RQP$ is a triangle on sphere \mathcal{F} .

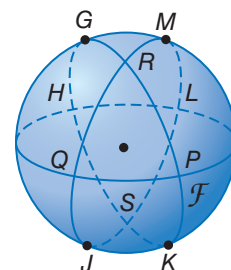

Guided Practice

Name each of the following on sphere \mathcal{F} above.

- 1A. two lines containing point P
- 1B. a segment containing point Q
- 1C. a triangle





Real-World Example 2 Identify Lines in Spherical Geometry

ENTERTAINMENT Determine whether figure m on the mirror ball shown is a line in spherical geometry.

Notice that figure m does not go through the poles of the sphere. Therefore figure m is not a great circle and so not a line in spherical geometry.

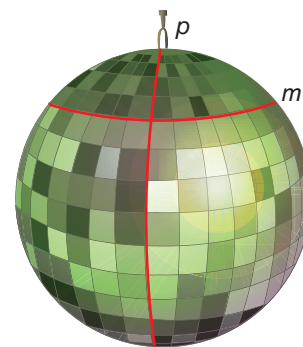

Guided Practice

2. Determine whether figure p on the mirror ball shown is a line in spherical geometry.

StudyTip

Elliptical Geometry Spherical geometry is a subcategory of elliptical geometry.

2 Comparing Euclidean and Spherical Geometries While some postulates and properties of Euclidean geometry are true in spherical geometry, others are not, or are true only under certain circumstances.



Example 3 Compare Plane Euclidean and Spherical Geometries

Tell whether the following postulate or property of plane Euclidean geometry has a corresponding statement in spherical geometry. If so, write the corresponding statement. If not, explain your reasoning.

- a. Through any two points, there is exactly one line.

In the figure, notice that there is more than one great circle (line) through polar points A and B . However, there is only one great circle through nonpolar points C and D .

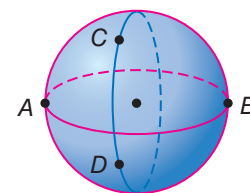

Therefore, a corresponding statement is that through any two nonpolar points, there is exactly one great circle (line).

- b. If given a line and a point not on the line, then there exists exactly one line through the point that is parallel to the given line.

In the figure, notice that every great circle (line) containing point A will intersect line ℓ . Thus there exists no great circle through point A that is parallel to line ℓ .

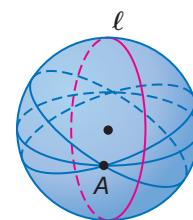

Guided Practice

- 3A. A line segment is the shortest path between two points.
3B. Through any two points, there is exactly one segment.

StudyTip

Finite Geometries Planar networks are another type of non-Euclidean geometry. You will learn about planar networks in Extend Lesson 13-6.

A **non-Euclidean geometry** is a geometry in which at least one of the postulates from Euclidean geometry fails. Notice in Example 3b that the Parallel Postulate does not hold true on a sphere. Lines, or great circles, cannot be parallel in spherical geometry. Therefore, spherical geometry is non-Euclidean.





Example 1 Name each of the following on sphere \mathcal{B} .

1. two lines containing point Q
2. a segment containing point L
3. a triangle
4. two segments on the same great circle

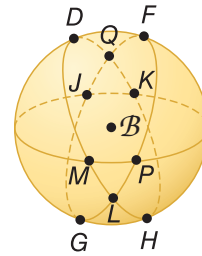

Example 2 **SPORTS** Determine whether figure \mathcal{X} on each of the spheres shown is a line in spherical geometry.

5

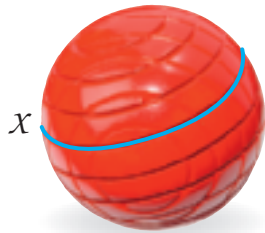

6.



Example 3

CCSS REASONING Tell whether the following postulate or property of plane Euclidean geometry has a corresponding statement in spherical geometry. If so, write the corresponding statement. If not, explain your reasoning.

7. The points on any line or line segment can be put into one-to-one correspondence with real numbers.
8. Perpendicular lines intersect at one point.

Practice and Problem Solving

Extra Practice is on page R12.

Example 1 Name two lines containing point M , a segment containing point S , and a triangle in each of the following spheres.

9.

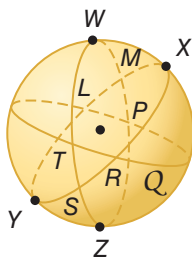

10.

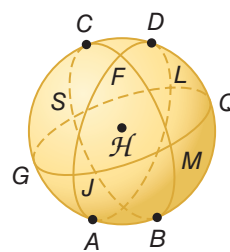

11. **SOCCER** Name each of the following on the soccer ball shown.

- a. two lines containing point B
- b. a segment containing point F
- c. a triangle
- d. a segment containing point C
- e. a line
- f. two lines containing point A

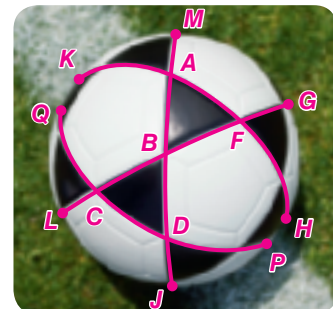

Example 2 **ARCHITECTURE** Determine whether figure w on each of the spheres shown is a line in spherical geometry.

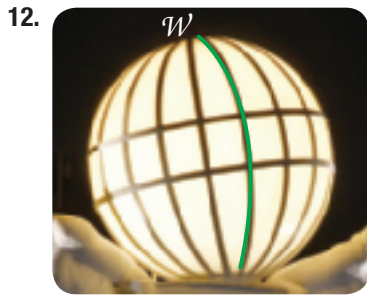

14. **CCSS MODELING** Lines of latitude and longitude are used to describe positions on the Earth's surface. By convention, lines of longitude divide Earth vertically, while lines of latitude divide it horizontally.
- Are lines of longitude great circles? Explain.
 - Are lines of latitude great circles? Explain.

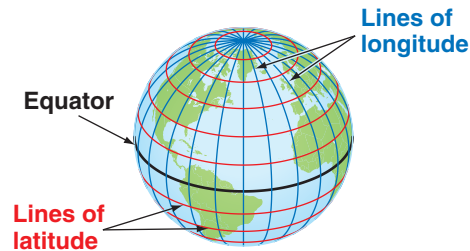

Example 3 Tell whether the following postulate or property of plane Euclidean geometry has a corresponding statement in spherical geometry. If so, write the corresponding statement. If not, explain your reasoning.

- A line goes on infinitely in two directions.
- Perpendicular lines form four 90° angles.
- If three points are collinear, exactly one is between the other two.
- If M is the midpoint of \overline{AB} , then $\overline{AM} \cong \overline{MB}$.

On a sphere, there are two distances that can be measured between two points. Use each figure and the information given to determine the distance between points J and K on each sphere. Round to the nearest tenth. Justify your answer.

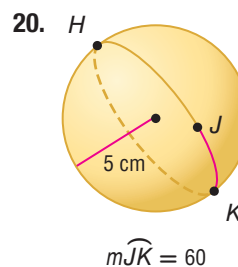
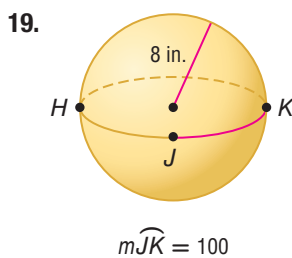

21. **GEOGRAPHY** The location of Phoenix, Arizona, is 112° W longitude, 33.4° N latitude, and the location of Helena, Montana, is 112° W longitude, 46.6° N latitude. West indicates the location in terms of the prime meridian, and north indicates the location in terms of the equator. The mean radius of Earth is about 3960 miles.
- Estimate the distance between Phoenix and Helena. Explain your reasoning.
 - Is there another way to express the distance between these two cities? Explain.
 - Can the distance between Washington, D.C., and London, England, which lie on approximately the same lines of latitude, be calculated in the same way? Explain your reasoning.
 - How many other locations are there that are the same distance from Phoenix, Arizona as Helena, Montana is? Explain.



22. **MULTIPLE REPRESENTATIONS** In this problem, you will investigate triangles in spherical geometry.

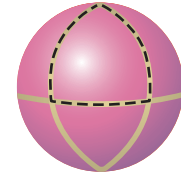

- Concrete** Use masking tape on a ball to mark three great circles. At least one of the three great circles should go through different poles than the other two. The great circles will form a triangle. Use a protractor to estimate the measure of each angle of the triangle.
- Tabular** Tabulate the measure of each angle of the triangle formed. Remove the tape and repeat the process two times so that you have tabulated the measure of three different triangles. Record the sum of the measures of each triangle.
- Verbal** Make a conjecture about the sum of the measures of a triangle in spherical geometry.

23. **QUADRILATERALS** Consider quadrilateral $ABCD$ on sphere \mathcal{P} . Note that it has four sides with $\overline{DC} \perp \overline{CB}$, $\overline{AB} \perp \overline{CB}$, and $\overline{DC} \cong \overline{AB}$.

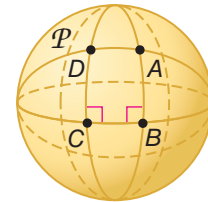

- Is $\overline{CD} \perp \overline{DA}$? Explain your reasoning.
- How does DA compare to CB ?
- Can a rectangle, as defined in Euclidean geometry, exist in non-Euclidean geometry? Explain your reasoning.

H.O.T. Problems Use Higher-Order Thinking Skills

24. **WRITING IN MATH** Compare and contrast Euclidean and spherical geometries. Be sure to include a discussion of planes and lines in both geometries.
25. **CHALLENGE** Geometries can be defined on curved surfaces other than spheres. Another type of non-Euclidean geometry is *hyperbolic geometry*. This geometry is defined on a curved saddle-like surface. Compare the sum of the angle measures of a triangle in hyperbolic, spherical, and Euclidean geometries.

Triangle in plane geometry

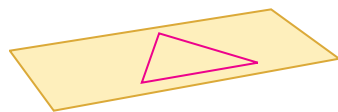

Triangle in spherical geometry

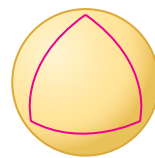

Triangle in hyperbolic geometry

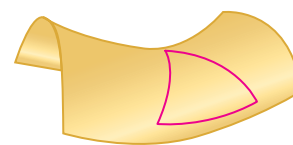

26. **OPEN ENDED** Sketch a sphere with three points so that two of the points lie on a great circle and two of the points do not lie on a great circle.
27. **CCSS ARGUMENTS** A *small circle* of a sphere intersects at least two points, but does not go through opposite poles. Points A and B lie on a small circle of sphere Q . Will two small circles *sometimes*, *always*, or *never* be parallel? Draw a sketch and explain your reasoning.

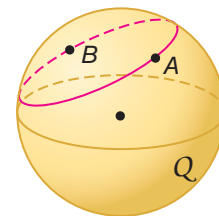

28. **WRITING IN MATH** Do similar or congruent triangles exist in spherical geometry? Explain your reasoning.
29. **REASONING** Is the statement *Spherical geometry is a subset of Euclidean geometry* true or false? Explain your reasoning.
30. **REASONING** Two planes are equidistant from the center of a sphere and intersect the sphere. What is true of the circles? Are they lines in spherical geometry? Explain.



Standardized Test Practice

31. Which of the following postulates or properties of spherical geometry is false?

- A The shortest path between two points on a circle is an arc.
- B If three points are collinear, any of the three points lies between the other two.
- C A great circle is infinite and never returns to its original starting point.
- D Perpendicular great circles intersect at two points.

32. **SAT/ACT** A car travels 50 miles due north in 1 hour and 120 miles due west in 2 hours. What is the average speed of the car?

- F 50 mph
- G 55 mph
- H 60 mph
- J none of the above

33. **SHORT RESPONSE** Name a line in sphere \mathcal{P} that contains point D .

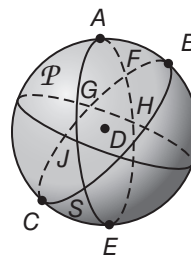

34. **ALGEBRA** The ratio of males to females in a classroom is 3:5. How many females are in the room if the total number of students is 32?

- A 12
- B 20
- C 29
- D 51
- E 53

Spiral Review

Find the volume of each sphere or hemisphere. Round to the nearest tenth. (Lesson 12-6)

- 35. sphere: area of great circle = 98.5 m^2
- 36. sphere: circumference of great circle $\approx 23.1 \text{ in.}$
- 37. hemisphere: circumference of great circle $\approx 50.3 \text{ cm}$
- 38. hemisphere: area of great circle $\approx 3416 \text{ ft}^2$

Find the volume of each cone. Round to the nearest tenth. (Lesson 12-5)

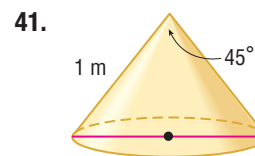
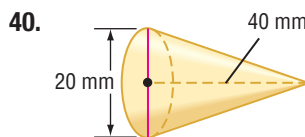
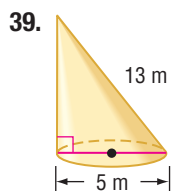

42. **RADIOS** Three radio towers are modeled by the points $A(-3, 4)$, $B(9, 4)$, and $C(-3, -12)$. Determine the location of another tower equidistant from all three towers, and write an equation for the circle which all three points lie on. (Lesson 10-8)

Skills Review

For each pair of similar figures, find the area of the green figure.

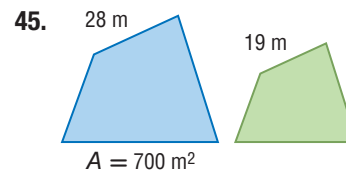
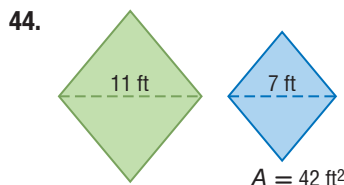
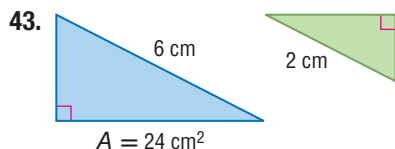



OBJECTIVE Use a latitude and longitude measure to identify the hemispheres on which the location lies and estimate the location of a city using a globe or map.

A grid system of imaginary lines on Earth is used for locating places and navigation. Imaginary vertical lines drawn around the Earth through the North and South Poles are called **meridians** and determine the measure of **longitude**. Imaginary horizontal lines parallel to the equator are called **parallels** and determine the measure of **latitude**.

The basic units for measurements are degrees, minutes, and seconds. 1 degree ($^{\circ}$) = 60 minutes ($'$), and 60 minutes = 60 seconds ($''$).



	Location of 0°	Direction	Maximum Degrees
Latitude (parallels)	equator	In northern hemisphere, all are degrees north. In southern hemisphere, all are degrees south.	180° at international dateline
Longitude (meridians)	Prime Meridian through Greenwich, England	In eastern hemisphere, all are degrees east. In western hemisphere, all are degrees west.	90° at each pole

Activity Investigate Latitude and Longitude

The table shows the latitude and longitude of three cities.

- In which hemisphere is each city located?
- Use a globe or map to name each city.
- Earth is approximately a sphere with a radius of 3960 miles. The equator and all meridians are great circles. The circumference of a great circle is equal to the length of the equator or any meridian. Find the length of a great circle on Earth in miles.
- Notice that the distance between each line of latitude is about the same. The distance from the equator to the North Pole is $\frac{1}{4}$ of the circumference of Earth, and each degree of latitude is $\frac{1}{90}$ of that distance. Estimate the distance between one pair of latitude lines in miles.

City	Latitude	Longitude
A	$37^{\circ}59'N$	$84^{\circ}28'W$
B	$34^{\circ}55'S$	$138^{\circ}36'E$
C	$64^{\circ}4'N$	$21^{\circ}58'W$

Analyze

The table shows the latitude and longitude of three cities.

- Name the hemisphere in which each city is located.
- Use a globe or map to name each city.
- Find the approximate distance between meridians at latitude of about $22^{\circ}N$. The direct distance between the two cities at the right is about 1646 miles.

City	Latitude	Longitude
F	$1^{\circ}28'S$	$48^{\circ}29'W$
G	$13^{\circ}45'N$	$100^{\circ}30'E$
H	$41^{\circ}17'S$	$174^{\circ}47'E$

Calcutta, India	$22^{\circ}34'N$	$88^{\circ}24'E$
Hong Kong, China	$22^{\circ}20'N$	$114^{\circ}11'E$

Congruent and Similar Solids

Then

- You compared surface areas and volumes of spheres.

Now

- Identify congruent or similar solids.
- Use properties of similar solids.

Why?

- The gemstones at the right are cut in exactly the same shape, but their sizes are different. Their shapes are *similar*.



New Vocabulary
similar solids
congruent solids

- Identify Congruent or Similar Solids** **Similar solids** have exactly the same shape but not necessarily the same size. All spheres are similar and all cubes are similar.

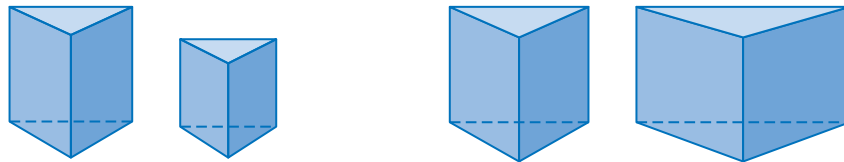

In similar solids, the corresponding linear measures, such as height and radius, have equal ratios. The common ratio is called the *scale factor*. If two similar solids are polyhedrons, their corresponding faces are similar.

KeyConcept Similar Solids

Words

Two solids are similar if they have the same shape and the ratios of their corresponding linear measures are equal.

Models

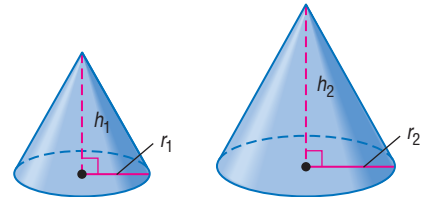

$$\frac{h_1}{h_2} = \frac{r_1}{r_2}$$

Congruent solids have exactly the same shape and the same size. Congruent solids are similar solids that have a scale factor of 1:1.

KeyConcept Congruent Solids

Words

Two solids are congruent if they have the following characteristics.

- Corresponding angles are congruent.
- Corresponding edges are congruent.
- Corresponding faces are congruent.
- Volumes are equal.

Models

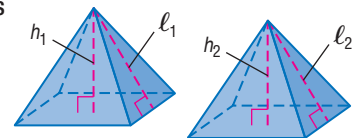

$$\frac{h_1}{h_2} = \frac{l_1}{l_2} = 1$$



StudyTip

Similar and Congruent Solids

If two solids are similar, then their corresponding linear measures are proportional. If two solids are congruent, then their corresponding linear measures are equal.

Example 1 Identify Similar and Congruent Solids

Determine whether each pair of solids is *similar*, *congruent*, or *neither*. If the solids are similar, state the scale factor.

a. the square pyramids

ratio of heights: $\frac{4}{6} = \frac{2}{3}$

ratio of base edges: $\frac{8}{12} = \frac{2}{3}$

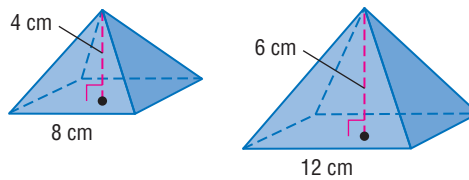

The ratios of the corresponding measures are equal, so the pyramids are similar. The scale factor is 2:3. Since the scale factor is not 1:1, the solids are not congruent.

b. the rectangular prisms

ratio of widths: $\frac{3}{1.7} \approx 1.76$

ratio of lengths: $\frac{6.2}{3.4} \approx 1.82$

ratio of heights: $\frac{2.5}{1.5} \approx 1.67$

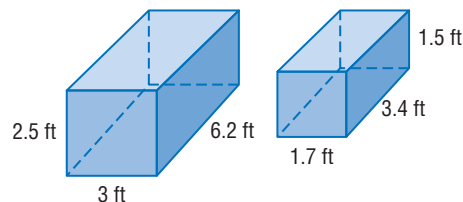

Since the ratios of corresponding measures are not equal, the prisms are neither congruent nor similar.

GuidedPractice

1A.

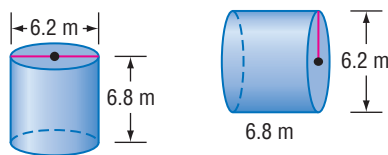

1B.

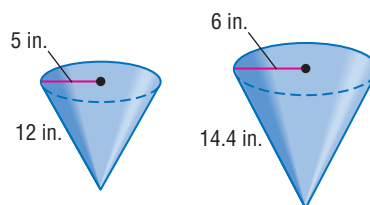

StudyTip

Check Solutions After finding missing measures of similar solids, work backward to check your solutions.

2 Properties of Congruent and Similar Solids

The cubes at the right are similar solids with a scale factor of 3:2.

ratio of surface areas: 54:24 or 9:4

ratio of volumes: 27:8

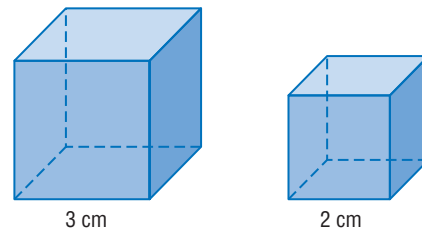

Notice that the ratio of surface areas, 9:4, can be written as $3^2:2^2$. The ratio of volumes, 27:8, can be written as $3^3:2^3$. This suggests the following theorem.

Theorem 12.1

Words If two similar solids have a scale factor of $a:b$, then the surface areas have a ratio of $a^2:b^2$, and the volumes have a ratio of $a^3:b^3$.

Examples scale factor 2:3
ratio of surface area 4:9
ratio of volumes 8:27

Models

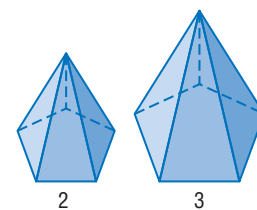

Figures must be similar in order for Theorem 12.1 to apply.





Example 2 Use Similar Solids to Write Ratios

Two similar cones have radii of 10 millimeters and 15 millimeters. What is the ratio of the surface area of the small cone to the surface area of the large cone?

First, find the scale factor.

$$\frac{\text{radius of small cone}}{\text{radius of large cone}} = \frac{10}{15} \text{ or } \frac{2}{3} \quad \text{Write a ratio comparing the radii.}$$

The scale factor is $\frac{2}{3}$.

$$\frac{a^2}{b^2} = \frac{2^2}{3^2} \text{ or } \frac{4}{9} \quad \text{If the scale factor is } \frac{a}{b}, \text{ then the ratio of surface areas is } \frac{a^2}{b^2}.$$

So, the ratio of the surface areas is 4:9.

StudyTip

Similar Solids and Area If two solids are similar, then the ratio of any corresponding areas is $a^2:b^2$. In Example 2, the ratio of the lateral areas of the cones is 4:25, and the ratio of the base areas of the cones is 4:25.

GuidedPractice

2. Two similar prisms have surface areas of 98 square centimeters and 18 square centimeters. What is the ratio of the height of the large prism to the height of the small prism?

Many real-world objects can be modeled by similar solids.



Real-World Example 3 Use Similar Solids to Find Unknown Values

CONTAINERS The containers at the right are similar cylinders. Find the height h of the smaller container.

Understand You know the height of the larger container and the volumes of both containers.

Plan Use Theorem 12.1 to write a ratio comparing the volumes. Then find the scale factor and use it to find h .

$$\begin{aligned} \text{Solve } \frac{\text{volume of small container}}{\text{volume of large container}} &= \frac{270\pi}{640\pi} && \text{Write a ratio comparing volumes.} \\ &= \frac{27}{64} && \text{Simplify.} \\ &= \frac{3^3}{4^3} && \text{Write as } \frac{a^3}{b^3}. \end{aligned}$$

The scale factor is 3:4.

$$\begin{aligned} \text{Ratio of heights} \rightarrow \frac{h}{10} &= \frac{3}{4} && \leftarrow \text{Scale factor} \\ h \cdot 4 &= 10 \cdot 3 && \text{Find the cross products.} \\ h &= 7.5 && \text{Solve for } h. \end{aligned}$$

So, the height of the smaller container is 7.5 inches.

Check Since $\frac{7.5}{10} = 0.75 = \frac{3}{4}$, the solution is correct. ✓

GuidedPractice

3. **VOLLEYBALL** A regulation volleyball has a circumference of about 66 centimeters. The ratio of the surface area of that ball to the surface area of a children's ball is approximately 1.6:1. What is the circumference of the children's ball? Round to the nearest centimeter.

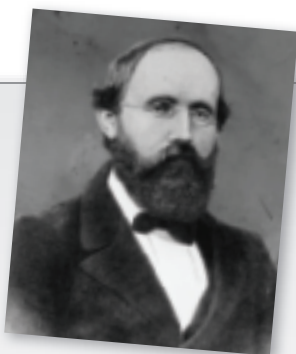
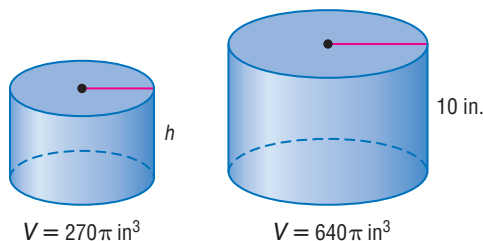

Math HistoryLink

Georg F.B. Riemann (1826–1866) Spherical geometry is sometimes called *Riemann geometry*, after Georg Riemann, a German mathematician responsible for the Riemannian Postulate, which states that through a point not on a line, there are no lines parallel to the given line.



Example 1 Determine whether each pair of solids is *similar*, *congruent*, or *neither*. If the solids are similar, state the scale factor.

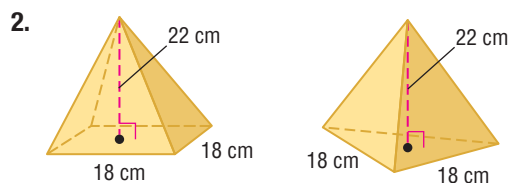
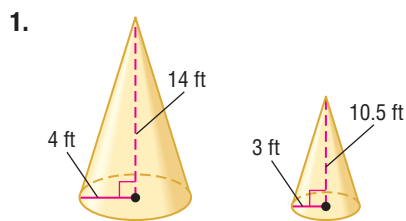

- Example 2**
- Two similar cylinders have radii of 15 inches and 6 inches. What is the ratio of the surface area of the small cylinder to the surface area of the large cylinder?
 - Two spheres have volumes of 36π cubic centimeters and 288π cubic centimeters. What is the ratio of the radius of the small sphere to the radius of the large sphere?

Example 3

- EXERCISE BALLS** A company sells two different sizes of exercise balls. The ratio of the diameters is 15:11. If the diameter of the smaller ball is 55 centimeters, what is the volume of the larger ball? Round to the nearest tenth.

Practice and Problem Solving

Extra Practice is on page R12.

Example 1 **CCSS REGULARITY** Determine whether each pair of solids is *similar*, *congruent*, or *neither*. If the solids are similar, state the scale factor.

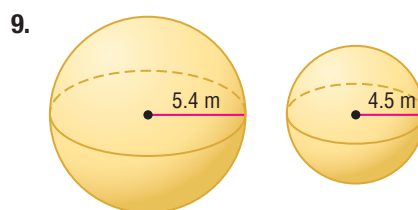
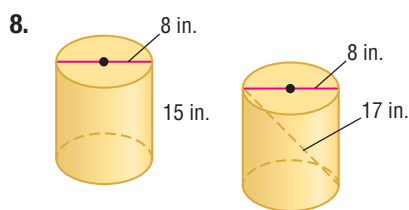
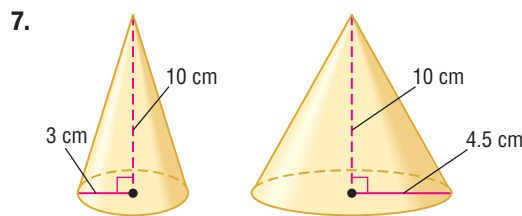
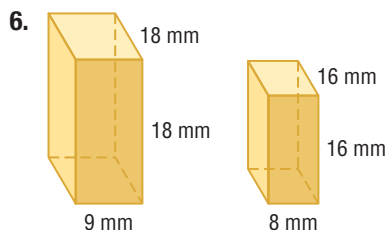

- Example 2**
- Two similar pyramids have slant heights of 6 inches and 12 inches. What is the ratio of the surface area of the small pyramid to the surface area of the large pyramid?
 - Two similar cylinders have heights of 35 meters and 25 meters. What is the ratio of the volume of the large cylinder to the volume of the small cylinder?
 - Two spheres have surface areas of 100π square centimeters and 16π square centimeters. What is the ratio of the volume of the large sphere to the volume of the small sphere?
 - Two similar hexagonal prisms have volumes of 250 cubic feet and 2 cubic feet. What is the ratio of the height of the large cylinder to the height of the small cylinder?
 - DIMENSIONAL ANALYSIS** Two rectangular prisms are similar. The height of the first prism is 6 yards and the height of the other prism is 9 feet. If the volume of the first prism is 810 cubic yards, what is the volume of the other prism?



Example 3

- 15. FOOD** A small cylindrical can of tuna has a radius of 4 centimeters and a height of 3.8 centimeters. A larger and similar can of tuna has a radius of 5.2 centimeters.
- What is the scale factor of the cylinders?
 - What is the volume of the larger can? Round to the nearest tenth.
- 16. SUITCASES** Two suitcases are similar rectangular prisms. The smaller suitcase is 68 centimeters long, 47 centimeters wide, and 27 centimeters deep. The larger suitcase is 85 centimeters long.
- What is the scale factor of the prisms?
 - What is the volume of the larger suitcase? Round to the nearest tenth.

- 17. SCULPTURE** The sculpture shown at the right is a scale model of a cornet. If the sculpture is 26 feet long and a standard cornet is 14 inches long, what is the scale factor of the sculpture to a standard cornet?



- 18.** The pyramids shown are congruent.
- What is the perimeter of the base of Pyramid A?
 - What is the area of the base of Pyramid B?
 - What is the volume of Pyramid B?

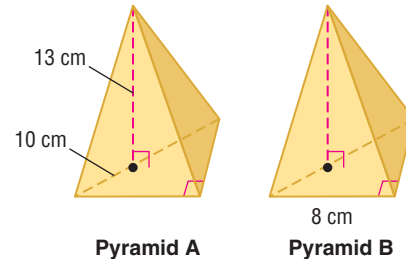

- 19. TECHNOLOGY** Jalissa and Mateo each have the same type of MP3 player, but in different colors. The players are congruent rectangular prisms. The volume of Jalissa's player is 4.92 cubic inches, the width is 2.4 inches, and the depth is 0.5 inch. What is the height of Mateo's player?

CCSS SENSE-MAKING Each pair of solids below is similar.

- 20.** What is the surface area of the smaller solid shown below?

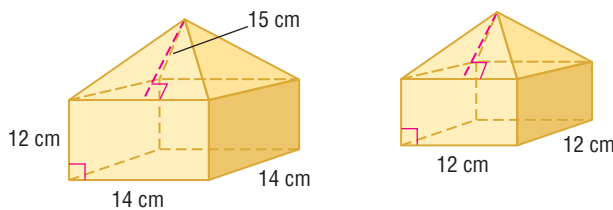

- 21.** What is the volume of the larger solid shown below?

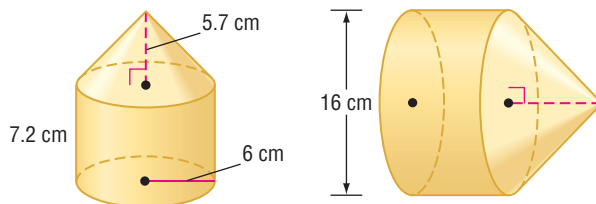

- 22. DIMENSIONAL ANALYSIS** Two cylinders are similar. The height of the first cylinder is 23 cm and the height of the other cylinder is 8 in. If the volume of the first cylinder is $552\pi \text{ cm}^3$, what is the volume of the other prism? Use $2.54 \text{ cm} = 1 \text{ in}$.



23. **DIMENSIONAL ANALYSIS** Two spheres are similar. The radius of the first sphere is 10 feet. The volume of the other sphere is 0.9 cubic meters. Use $2.54 \text{ cm} = 1 \text{ in.}$ to determine the scale factor from the first sphere to the second.
24. **ALGEBRA** Two similar cones have volumes of 343π cubic centimeters and 512π cubic centimeters. The height of each cone is equal to 3 times its radius. Find the radius and height of both cones.
25. **TENTS** Two tents are in the shape of hemispheres, with circular floors. The ratio of their floor areas is $9:12.25$. If the diameter of the smaller tent is 6 feet, what is the volume of the larger tent? Round to the nearest tenth.
26. **MULTIPLE REPRESENTATIONS** In this problem, you will investigate similarity. The heights of two similar cylinders are in the ratio 2 to 3. The lateral area of the larger cylinder is 162π square centimeters, and the diameter of the smaller cylinder is 8 centimeters.
- Verbal** What is the height of the larger cylinder? Explain your method.
 - Geometric** Sketch and label the two cylinders.
 - Analytical** How many times as great is the volume of the larger cylinder as the volume of the smaller cylinder?

H.O.T. Problems Use Higher-Order Thinking Skills

27. **ERROR ANALYSIS** Cylinder X has a diameter of 20 centimeters and a height of 11 centimeters. Cylinder Y has a radius of 30 centimeters and is similar to Cylinder X. Did Laura or Paloma correctly find the height of Cylinder Y? Explain your reasoning.

Laura

Cylinder X: radius 10,
height 11

Cylinder Y: radius 30,
height a

$$\frac{10}{30} = \frac{11}{a}, \text{ so } a = 33.$$

Paloma

Cylinder X: diameter 20,
height 11

Cylinder Y: diameter 20,
height a

$$\frac{20}{20} = \frac{11}{a}, \text{ so } a = 11.$$

28. **CHALLENGE** The ratio of the volume of Cylinder A to the volume of Cylinder B is $1:5$. Cylinder A is similar to Cylinder C with a scale factor of $1:2$ and Cylinder B is similar to Cylinder D with a scale factor of $1:3$. What is the ratio of the volume of Cylinder C to the volume of Cylinder D? Explain your reasoning.
29. **WRITING IN MATH** Explain how the surface areas and volumes of the similar prisms shown at the right are related.
30. **OPEN ENDED** Describe two nonsimilar triangular pyramids with similar bases.
31. **CCSS SENSE-MAKING** Plane \mathcal{P} is parallel to the base of cone C, and the volume of the cone above the plane is $\frac{1}{8}$ of the volume of cone C. Find the height of cone C.
32. **WRITING IN MATH** Explain why all spheres are similar.

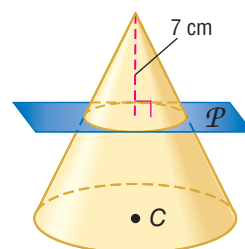
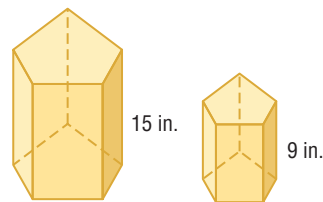

Standardized Test Practice

33. Two similar spheres have radii of 20π meters and 6π meters. What is the ratio of the surface area of the large sphere to the surface area of the small sphere?

A $\frac{100}{3}$ B $\frac{100}{9}$ C $\frac{10}{3}$ D $\frac{10}{9}$

34. What is the scale factor of the similar figures?

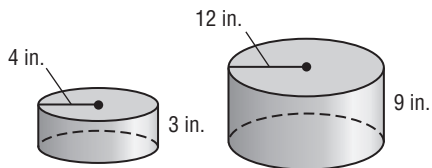

F 0.25 H 0.5
G 0.33 J 0.75

35. **SHORT RESPONSE** Point A and point B represent the locations of Timothy's and Quincy's houses. If each unit on the map represents one kilometer, how far apart are the two houses?

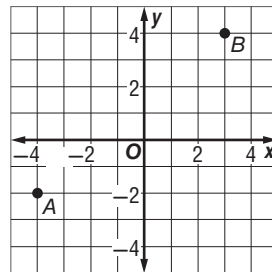

36. **SAT/ACT** If $\frac{x+2}{3} = \frac{(x+2)^2}{15}$, what is one possible value of x ?

A 0 B 1 C 2 D 3 E 4

Spiral Review

Determine whether figure χ on each of the spheres shown is a line in spherical geometry. (Lesson 12-7)

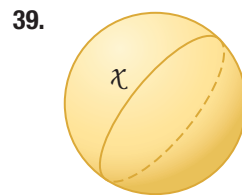
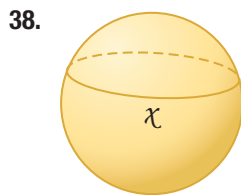
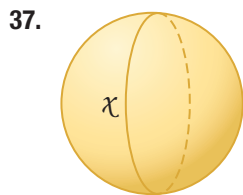

40. **ENTERTAINMENT** Some people think that the Spaceship Earth geosphere at Epcot in Disney World in Orlando, Florida, resembles a golf ball. The building is a sphere measuring 165 feet in diameter. A typical golf ball has a diameter of approximately 1.5 inches. (Lesson 12-6)

- Find the volume of Spaceship Earth to the nearest cubic foot.
- Find the volume of a golf ball to the nearest tenth.
- What is the scale factor that compares Spaceship Earth to a golf ball?
- What is the ratio of the volumes of Spaceship Earth to a golf ball?



Find x . Assume that segments that appear to be tangent are tangent. (Lesson 10-7)

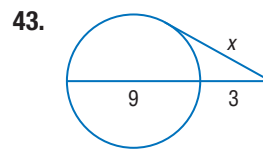
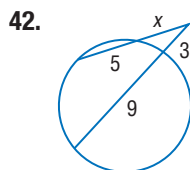
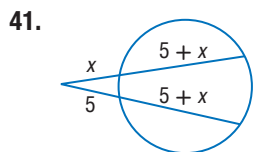

Skills Review

Express each fraction as a decimal to the nearest hundredth.

44. $\frac{8}{13}$

45. $\frac{17}{54}$

46. $\frac{11}{78}$

47. $\frac{43}{46}$

Study Guide

Key Concepts

Representations of Three-Dimensional Figures

(Lesson 12-1)

- Solids can be classified by bases, faces, edges, and vertices.

Surface Areas of Prisms and Cylinders

(Lesson 12-2)

- Lateral surface area of a right prism: $L = Ph$
- Lateral surface area of a right cylinder: $L = 2\pi rh$

Surface Areas of Pyramids and Cones

(Lesson 12-3)

- Lateral surface area of a pyramid: $L = \frac{1}{2}P\ell$
- Lateral surface area of a right cone: $L = \pi r\ell$

Volumes of Prisms and Cylinders

(Lesson 12-4)

- Volume of prism or cylinder: $V = Bh$

Volumes of Pyramids and Cones

(Lesson 12-5)

- Volume of a pyramid: $V = \frac{1}{3}Bh$
- Volume of a cone: $V = \frac{1}{3}\pi r^2 h$

Surface Areas and Volumes of Spheres

(Lesson 12-6)

- Surface area of a sphere: $S = 4\pi r^2$
- Volume of a sphere: $V = \frac{4}{3}\pi r^3$

Congruent and Similar Solids

(Lesson 12-8)

- Similar solids have the same shape, but not necessarily the same size.
- Congruent solids are similar solids with a scale factor of 1.

FOLDABLES® Study Organizer

Be sure the Key Concepts are noted in your Foldable.

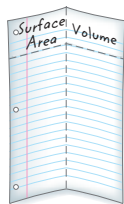

Key Vocabulary



- | | |
|-----------------------------|---------------------------------|
| altitude (p. 846) | lateral face (p. 846) |
| axis (p. 848) | non-Euclidean geometry (p. 890) |
| base edges (p. 846) | oblique cone (p. 856) |
| composite solid (p. 852) | oblique solid (p. 838) |
| congruent solid (p. 896) | regular pyramid (p. 854) |
| cross section (p. 840) | right cone (p. 856) |
| Euclidean geometry (p. 889) | right solid (p. 837) |
| great circle (p. 881) | similar solids (p. 896) |
| isometric view (p. 839) | slant height (p. 854) |
| lateral area (p. 846) | spherical geometry (p. 889) |
| lateral edge (p. 846) | topographic map (p. 845) |

Vocabulary Check

State whether each sentence is *true* or *false*. If *false*, replace the underlined term to make a true sentence.

- Euclidean geometry deals with a system of points, great circles (lines), and spheres (planes).
- Similar solids have exactly the same shape, but not necessarily the same size.
- A right solid has an axis that is also an altitude.
- The isometric view is when an object is viewed from a corner.
- The perpendicular distance from the base of a geometric figure to the opposite vertex, parallel side, or parallel surface is the altitude.
- Rotation symmetry is also called mirror symmetry.
- The intersection of two adjacent lateral faces is the lateral edge.
- Euclidean geometry refers to geometrical systems that are not in accordance with the Parallel Postulate.
- A composite solid is a three-dimensional figure that is composed of simpler figures.
- The slant height is the height of each lateral face of a pyramid or cone.



Lesson-by-Lesson Review

12-1 Representations of Three-Dimensional Figures

Describe each cross section.

11.

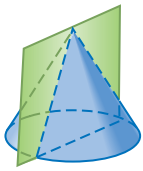

12.

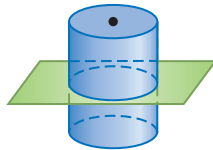

13. **CAKE** The cake shown is cut in half vertically. Describe the cross section of the cake.



Example 1

Describe the vertical and horizontal cross sections of the figure shown below.

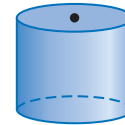

The vertical cross section is a rectangle.
The horizontal cross section is a circle.

12-2 Surface Areas of Prisms and Cylinders

Find the lateral area and surface area of each prism. Round to the nearest tenth if necessary.

14.

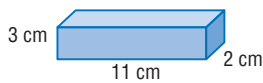

15.

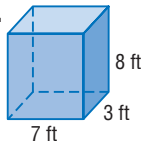

Find the lateral area and surface area of each cylinder. Round to the nearest tenth.

16.

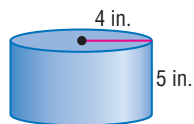

17.

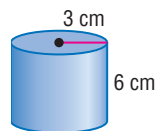

Example 2

Find the surface area of the rectangular prism.

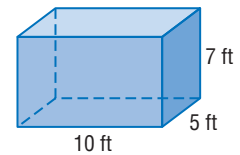

Use the 10-foot by 5-foot rectangle as the base.

$$S = Ph + 2B$$

$$= (2 \cdot 10 + 2 \cdot 5)(7) + 2(10 \cdot 5)$$

$$= 310$$

The surface area is 310 square feet.

Surface area of a prism

Substitution

Simplify.

12-3 Surface Areas of Pyramids and Cones

Find the lateral area and the surface area of each regular pyramid. Round to the nearest tenth.

18.

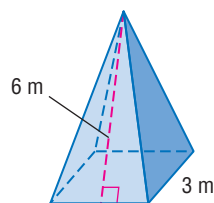

19.

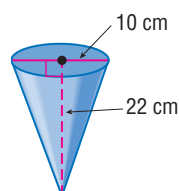

Example 3

Find the surface area of the square pyramid. Round to the nearest tenth.

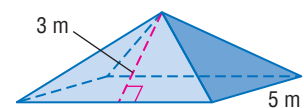

$$S = \frac{1}{2}P\ell + B$$

$$= \frac{1}{2}(4 \cdot 5)3 + 5 \cdot 5$$

$$= 55$$

The surface area is 55 square feet.

Surface area of a regular pyramid

$$P = 4 \cdot 5 \text{ or } 20, \ell = 3, B = 4 \cdot 5$$

Simplify.

12-4 Volumes of Prisms and Cylinders

20. The volume of a cylinder is 770 cm^3 . It has a height of 5 cm. Find its radius.
21. Find the volume of the triangular prism.

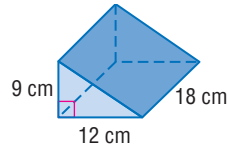

22. **TRAILERS** A semi-truck trailer is basically a rectangular prism. A typical height for the inside of these trailers is 108 inches. If the trailer is 8 feet wide and 20 feet long, what is the volume of the trailer?

Example 4

Find the volume of the cylinder.

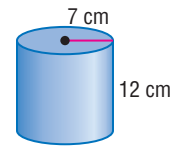

$$\begin{aligned} V &= \pi r^2 h \\ &= \pi(7)^2(12) \\ &\approx 1847.5 \end{aligned}$$

Volume of a cylinder

$$r = 7 \text{ and } h = 12$$

Use a calculator.

The volume is approximately 1847.5 cubic centimeters.

12-5 Volumes of Pyramids and Cones

23. Find the volume of a cone that has a radius of 1 cm and a height of 3.4 cm.
24. Find the volume of the regular pyramid.

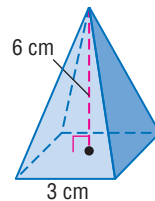

25. **ARCHITECTURE** The Great Pyramid measures 756 feet on each side of the base and the height is 481 feet. Find the volume of the pyramid.

Example 5

Find the volume of the pyramid.

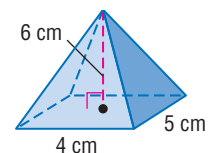

$$\begin{aligned} V &= \frac{1}{3} Bh \\ &= \frac{1}{3}(4 \cdot 5)(6) \\ &= 40 \end{aligned}$$

Volume of a pyramid

$$B = 4 \cdot 5 \text{ and } h = 6$$

Simplify.

The volume is 40 cubic centimeters.

12-6 Surface Areas and Volumes of Spheres

Find the surface area of each figure.

26.

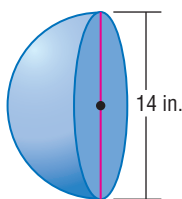

27.

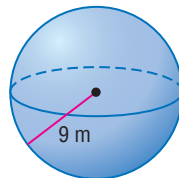

Find the volume of each sphere or hemisphere. Round to the nearest tenth.

28. hemisphere: circumference of great circle = 24π m
29. sphere: area of great circle = $55\pi \text{ in}^2$
30. **CONSTRUCTION** Cement is poured into a hemisphere that is 6 cm across. What is the volume of cement used?

Example 6

Find the surface area and volume of the sphere. Round to the nearest tenth.

$$\begin{aligned} S &= 4\pi r^2 \\ &= 4\pi(14)^2 \\ &\approx 2463 \end{aligned}$$

Surface area of a sphere

Substitute.

Use a calculator.

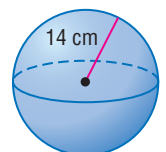

The surface area is about 2463 square centimeters.

$$\begin{aligned} V &= \frac{4}{3}\pi r^3 \\ &= \frac{4}{3}\pi(14)^3 \\ &\approx 11,494 \text{ cm}^3 \end{aligned}$$

Volume of a sphere

Replace r with 9.

Use a calculator.

The volume is about 11,494 cubic centimeters.

12-7 Spherical Geometry

Name each of the following on sphere *A*.

- 31. two lines containing point *C*
- 32. a segment containing point *H*
- 33. a triangle containing point *B*
- 34. two lines containing point *L*
- 35. a segment containing point *J*
- 36. a triangle containing point *K*

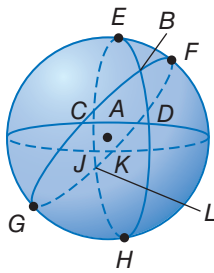

- 37. **MARBLES** Determine whether figure *y* on the sphere shown is a line in spherical geometry.

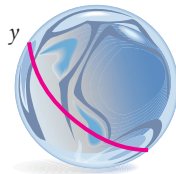

Example 7

Name each of the following on sphere *A*.

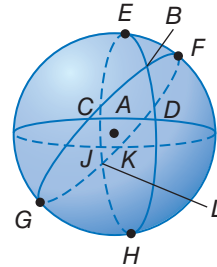

- a. two lines containing point *D*
 $\overleftrightarrow{EH}, \overleftrightarrow{CK}$
- b. a segment containing point *E*
DJ

12-8 Congruent and Similar Solids

Determine whether each pair of solids is *similar*, *congruent*, or *neither*. If the solids are similar, state the scale factor.

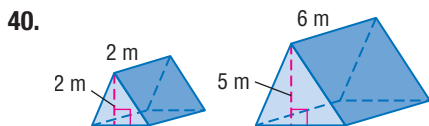
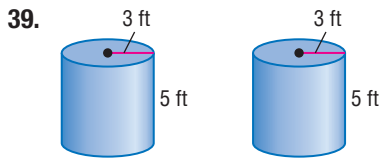
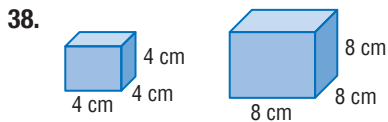

- 42. **MODELS** A collector's model car is scaled so that 1 inch on the model equals $5\frac{3}{4}$ feet on the actual car. If the model is $\frac{4}{5}$ inches high, how high is the actual car?

Example 8

Determine whether each pair of solids is similar, congruent, or neither. If the solids are similar, state the scale factor.

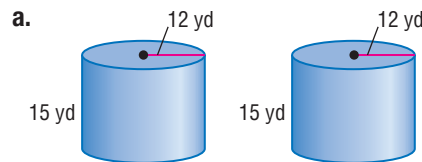

The ratios of the corresponding measures are equal and the scale factor is 1 : 1, so the solids are congruent.

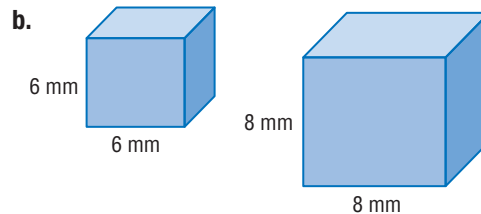

ratio of widths: $\frac{6}{8} = 0.75$

ratio of heights: $\frac{6}{8} = 0.75$

The ratios of the corresponding measures are equal, so the cubes are similar. The scale factor is 3 : 4. Since the scale factor is not 1 : 1, the solids are not congruent.

1. Use isometric dot paper and the orthographic drawings to sketch the solid.

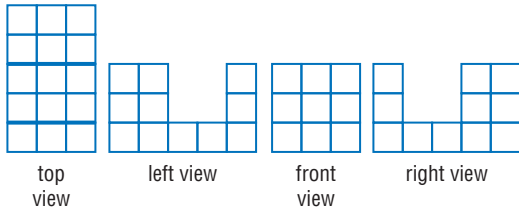

2. Describe the cross section.

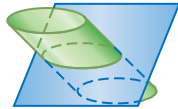

3. **SHORT RESPONSE** Find the surface area of the tent model. Round to the nearest tenth if necessary.

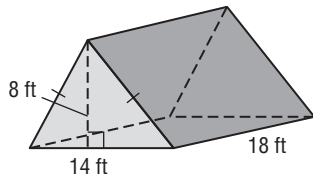

4. **CANDLES** A circular pillar candle is 2.8 inches wide and 6 inches tall. What are the lateral area and surface area of the candle? Round to the nearest tenth if necessary.

5. **TEA** A tea bag is shaped like a regular square pyramid. Each edge of the base is 4 centimeters, and the slant height is 5 centimeters. What is the surface area of the tea bag in square centimeters? Round to the nearest tenth if necessary.

6. **BEEHIVE** Estimate the lateral area and surface area of the Turkish beehive room. Round to the nearest tenth if necessary.

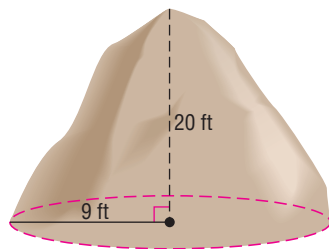

7. Find the volume of the candle in Exercise 4. Round to the nearest tenth if necessary.
8. Find the volume of the tea bag in Exercise 5. Round to the nearest tenth if necessary.

9. **EARTH** Earth's radius is approximately 6400 kilometers. What are the surface area and volume of the Earth? Round to the nearest tenth if necessary.



10. **SOFTBALL** A regulation softball has a circumference of 12 inches. What is the volume of the softball?

Name each of the following on sphere \mathcal{A} .

11. two lines containing point S
12. a segment containing point L
13. a triangle
14. two lines containing point D
15. a segment containing point P

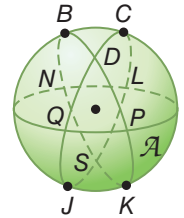

16. Are these two cubes *similar*, *congruent*, or *neither*? Explain your reasoning.

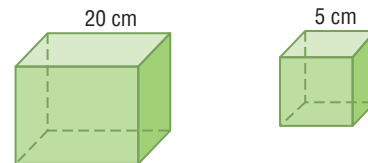

17. Two similar cylinders have heights of 75 centimeters and 25 centimeters. What is the ratio of the volume of the large cylinder to the volume of the small cylinder?
18. **BAKING** Two spherical pieces of cookie dough have radii of 3 centimeters and 5 centimeters, respectively. The pieces are combined to form one large spherical piece of dough. What is the approximate radius of the new sphere of dough? Round to the nearest tenth.
19. **ALGEBRA** A rectangular prism has a base with side lengths x and $x + 3$ and height $2x$. Find the surface area and volume of the prism.

20. **TRANSPORTATION** The traffic cone is 19 inches tall and has a radius of 5 inches.

- a. Find the lateral area.
- b. Find the surface area.

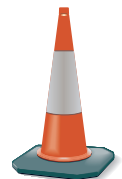

Make a Drawing

Making a drawing can be a very helpful way for you to visualize how to solve a problem. Sketch your drawings on scrap paper or in your test booklet (if allowed). Do not make any marks on your answer sheet other than your answers.

Strategies for Making a Drawing

Step 1

Read the problem statement carefully.

Ask yourself:

- What am I being asked to solve? What information is given?
- Would making a drawing help me visualize how to solve the problem?

Step 2

Sketch and label your drawing.

- Make your drawing as clear and accurate as possible.
- Label the drawing carefully. Be sure to include all of the information given in the problem statement.
- Fill in your drawing with information that can be gained from intermediate calculations.



Standardized Test Example

Solve the problem below. Responses will be graded using the short-response scoring rubric shown.

A regular pyramid has a square base with 10-centimeter sides and a height of 12 centimeters. What is the total surface area of the pyramid? Round to the nearest tenth if necessary.

Scoring Rubric	
Criteria	Score
Full Credit: The answer is correct and a full explanation is provided that shows each step.	2
Partial Credit: <ul style="list-style-type: none"> • The answer is correct, but the explanation is incomplete. • The answer is incorrect, but the explanation is correct. 	1

Read the problem statement carefully. You are given the dimensions of a square pyramid and asked to find the surface area. Sketching a drawing may help you visualize the problem and how to solve it.

Example of a 2-point response:

Use the Pythagorean Theorem to find the slant height, ℓ .

$$\ell^2 = 5^2 + 12^2$$

$$\ell^2 = 169$$

$$\ell = 13$$

Find the lateral area.

$$\begin{aligned} L &= \frac{1}{2}P\ell \\ &= \frac{1}{2}(40)(13) \\ &= 260 \end{aligned}$$

Add the area of the square base.

$$S = 260 + 100 \text{ or } 360$$

The total surface area is 360 square centimeters.

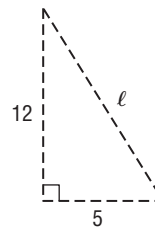
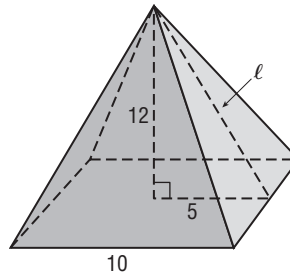

The steps, calculations, and reasoning are clearly stated. The student also arrives at the correct answer. So, this response is worth the full 2 points.

Exercises

Solve each problem. Show your work. Responses will be graded using the short-response scoring rubric given at the beginning of the lesson.

- A right circular cone has a slant height that is twice its radius. The lateral area of the cone is about 569 square millimeters. What is the radius of the cone? Round to the nearest whole millimeter.
- From a single point in her yard, Marti measures and marks distances of 18 feet and 30 feet with stakes for two sides of her garden. How far apart should the two stakes be if the garden is to be rectangular shaped?
- A passing boat is 310 feet from the base of a lighthouse. The angle of depression from the top of the lighthouse is 24° . What is the height of the lighthouse to the nearest tenth of a foot?
- A regular hexagon is inscribed in a circle with a diameter of 12 centimeters. What is the exact area of the hexagon?
- Luther is building a model rocket for a science fair project. He attaches a nosecone to a cylindrical body to form the rocket's fuselage. The rocket has a diameter of 4 inches and a total height (including the nosecone) of 2 feet 5 inches. The nosecone is 7 inches tall. What is the volume of the rocket? Give your answer rounded to the nearest tenth cubic inch.
- Terry wants to measure the height of the top of the backboard of his basketball hoop. At 4:00, the shadow of a 4-foot fence post is 20 inches long, and the shadow of the backboard is 65 inches long. What is the height of the top of the backboard?

Standardized Test Practice

Cumulative, Chapters 1 through 12

Multiple Choice

Read each question. Then fill in the correct answer on the answer document provided by your teacher or on a sheet of paper.

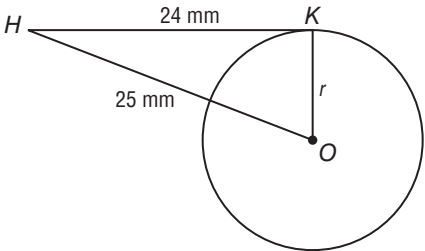
- The Great Pyramid of Giza in Egypt originally had a height of about 148 meters. The base of the pyramid was a square with 230-meter sides. What was the original volume of the pyramid? Round to the nearest whole number.
 - 1,786,503 m³
 - 2,609,733 m³
 - 104,128,752 m³
 - 122,716,907 m³
- If \overline{HK} is tangent to circle O , what is the radius of the circle?
 
 - 7 mm
 - 8 mm
 - 9 mm
 - 10 mm

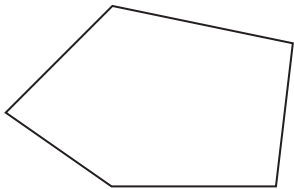
- What is the sum of the interior angles of the figure?
 
 - 450°
 - 540°
 - 630°
 - 720°

Test-Taking Tip

Question 1 You can eliminate some unreasonable answers by estimating first. Choices C and D are too large.

- Eddie conducted a random survey of 50 students and found that 14 of them spend more than 2 hours each night doing homework. If there are 421 students at Eddie's school, predict how many of them spend more than 2 hours each night doing homework.

F 118	H 125
G 124	J 131

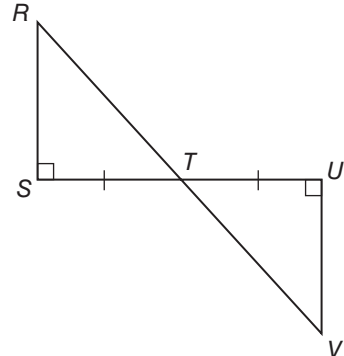
- \overline{RS} represents the height of Mount Mitchell, the highest point in the state of North Carolina. If $TU = 5013$ feet, $UV = 6684$ feet, and $TV = 8355$ feet, use the ASA Theorem to find the height of Mount Mitchell.
 
 - 5013 ft
 - 6684 ft
 - 7154 ft
 - 8355 ft

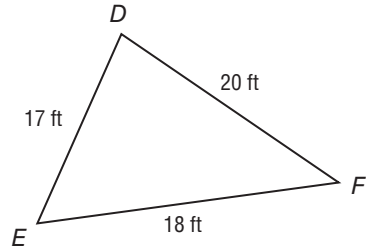
- Triangle DEF is shown below.
 
 - $m\angle F > m\angle D$
 - $m\angle E > m\angle F$
 - $m\angle D < m\angle F$
 - $m\angle E < m\angle D$

Which statement about this triangle is true?

- $m\angle F > m\angle D$
- $m\angle E > m\angle F$
- $m\angle D < m\angle F$
- $m\angle E < m\angle D$

Short Response/Gridded Response

Record your answers on the answer sheet provided by your teacher or on a sheet of paper.

7. Suppose the length of one diagonal of a kite is three times the length of the other diagonal. If the area of the kite is 96 square inches, what are the lengths of the diagonals? Show your work.
8. Copy the figure and point Y . Then use a protractor and ruler to draw the rotation of the figure 75° clockwise about point Y .



9. **GRIDDED RESPONSE** What is the perimeter of the isosceles triangle to the nearest tenth of a centimeter?

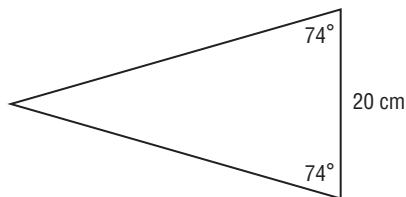

10. Determine whether the following statement is *sometimes*, *always*, or *never* true. Explain.

The orthocenter of a right triangle is located at the vertex of the right angle.

11. **GRIDDED RESPONSE** Given: $c \parallel d$

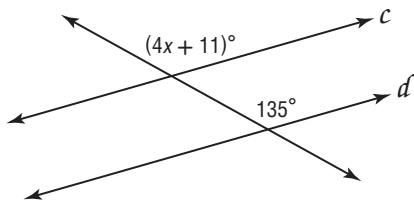

What is the value of x in the figure?

12. What is the lateral area of the square pyramid below? Round to the nearest tenth if necessary. Show your work.

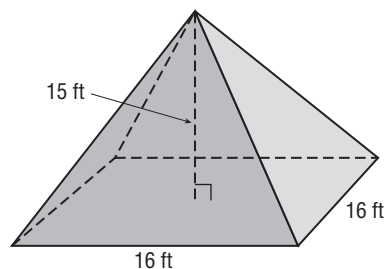

Extended Response

Record your answers on a sheet of paper. Show your work.

13. The two prisms below are similar figures.

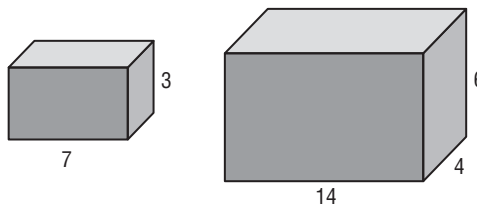

- What is the scale factor from the smaller prism to the larger one?
- What are the volumes of the prisms?
- How many times as great is the volume of the larger prism as the smaller prism?
- Suppose a solid figure has a volume of 40 cubic units. If its dimensions are scaled by a factor of 1.5, what will the volume of the new figure be?

Need ExtraHelp?

If you missed Question...	1	2	3	4	5	6	7	8	9	10	11	12	13
Go to Lesson...	12-5	10-5	6-1	7-1	4-5	5-3	11-2	9-3	8-4	5-2	3-2	12-3	12-8

