

## MCAP ... Grade 5 Practice (Section 4)



### Mathematics

---

**1** A contractor measured the length and the width of two rectangular pieces of land.

- The two pieces of land are adjacent and share the same width of 17 yards.
- The first piece of land has a length of  $32\frac{1}{3}$  yards.
- The second piece of land has a length of  $25\frac{1}{4}$  yards.

Which steps should the contractor use to determine the area, in square yards, of the two pieces of land altogether?

- A** Add  $32\frac{1}{3}$  and  $25\frac{1}{4}$  and then add the result by 17.
- B** Multiply  $32\frac{1}{3}$  and  $25\frac{1}{4}$  and then add the result by 17.
- C** Add  $32\frac{1}{3}$  and  $25\frac{1}{4}$  and then multiply the result by 17.
- D** Multiply  $32\frac{1}{3}$  and  $25\frac{1}{4}$  and then multiply the result by 17.



2 A student made the following claim.

"If a quadrilateral has two pairs of congruent sides, then the figure is a parallelogram."

Which **two** figures can be used to show that the student's claim is incorrect?

Select the **two** correct answers.

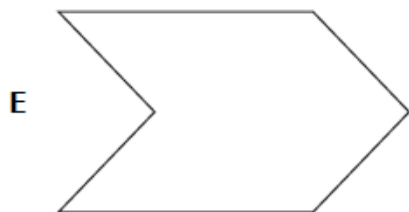
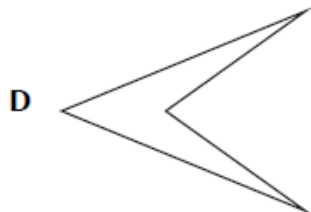
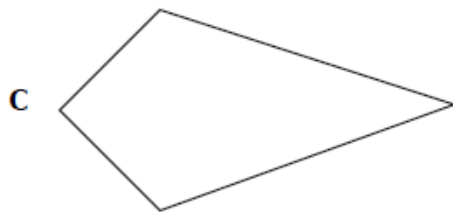
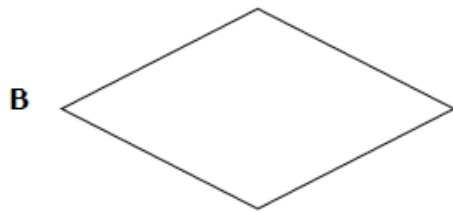

## MCAP ... Grade 5 Practice (Section 4)



### Mathematics

---

- 3 Bernard stacked two gift boxes that are each in the shape of a right rectangular prism. The dimensions of the resulting shape are shown.

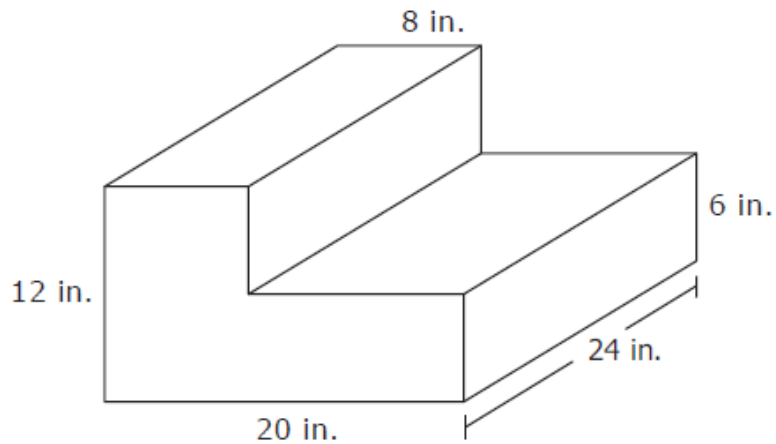

What is the total volume, in cubic inches, of the gift boxes?

Enter your answer, and your work or explanation in the space provided.

# MCAP ... Grade 5 Practice (Section 4)



- 4 An artist is using a squared wooden panel to create a piece of art. The panel is divided in smaller squares as shown.

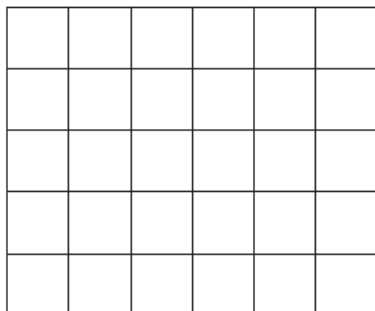

The artist paints  $\frac{3}{5}$  of the squares in red, then draws golden circles on  $\frac{1}{3}$  of the painted squares to decorate it.

The artist draws the model shown to represent the fraction of the whole wooden panel that is both painted and decorated.

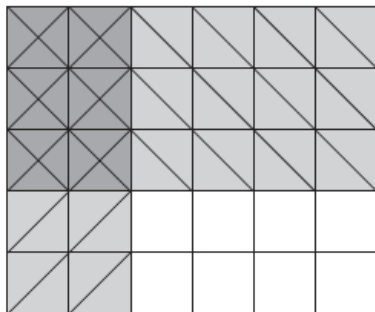

Which statement is true about the model the artist drew?

- A The model is correct because it represents the equation  $\frac{3}{5} + \frac{2}{6} = \frac{6}{30}$ .
- B The model is correct because it represents the equation  $\frac{3}{5} \times \frac{1}{3} = \frac{1}{5}$  and  $\frac{1}{5}$  of 30 is 6.
- C The model is incorrect because 2 of the 6 columns are shaded and there should be 3 columns with 1 column shaded.
- D The model is incorrect because  $\frac{3}{5} \times \frac{1}{3} = \frac{1}{5}$  and  $\frac{1}{5}$  of the model can only be represented by shading 1 row of squares.

## MCAP ... Grade 5 Practice (Section 4)



### Mathematics

---

5 A teacher needs to buy batteries for 32 calculators.

- There are 20 basic calculators that each require 3 batteries.
- There are 12 advanced calculators that each require 4 batteries.
- The batteries are sold in packages of 24.

The teacher thinks that 6 packages of batteries will be needed and that there will be 12 batteries left over after the calculators are filled.

Provide a solution path that shows whether the teacher is correct or incorrect. Explain what each step in the solution path represents in terms of the situation.

Enter your answer and your work or explanation in the space provided.

6 During a 5-day paper recycling drive, the students in a classroom collected 12.4 pounds of paper each day for 4 days and 8.39 pounds of paper on the fifth day.

Which steps can be used to find the total number of pounds of paper the students collected for the recycling drive?

- A** Multiply 12.4 by 4, then add 8.39.
- B** Multiply 12.4 by 5, then add 8.39.
- C** Add 12.4 and 8.39, then multiply the result by 4.
- D** Add 12.4 and 8.39, then multiply the result by 5.

**Answers**

Item Number	Answer Key
1.	C
2.	C, D
3.	<p><b><u>Sample Top Score Response</u></b></p> <p>The volume of the top box is <math>8 \times 24 \times 6 = 1152</math> cubic inches.</p> <p>The volume of the bottom box is <math>20 \times 24 \times 6 = 2880</math> cubic inches.</p> <p>The total volume of the boxes is <math>1152 + 2880 = 4032</math> cubic inches.</p> <p><b>Refer to the Holistic Rubric for 3-Point Modeling Constructed Response Items for score point information.</b></p>
4.	B

**Answers**

Item Number	Answer Key
5.	<p><b><u>Sample Top Score Response</u></b></p> <p>The 20 basic calculators require a total of <math>20 \times 3 = 60</math> batteries. The 12 advanced calculators require a total of <math>12 \times 4 = 48</math> batteries. In total, the teacher needs <math>60 + 48 = 108</math> batteries.</p> <p>Dividing, <math>108 \div 24 = 4.5</math>. Therefore, the teacher needs to buy 5 packages of batteries. The teacher's thinking that 6 packages of batteries is incorrect.</p> <p>5 packages contain a total of <math>5 \times 24 = 120</math> batteries, so the teacher will have <math>120 - 108 = 12</math> batteries left over.</p> <p><b>Refer to the Holistic Rubric for 4-Point Reasoning Constructed Response Items for score point information.</b></p>
6.	A